



EBARA

Ego

HIGH PERFORMANCE ELECTRONIC CIRCULATORS



GENERAL FEATURES

“Ego” is a cutting-edge range of electronic circulators that fully comply with European Directive EuP/ErP CE 641/2009. All Ego circulators feature the **ECM technology (electronically commuted motor with rotor equipped with permanent magnets)**, that enables automatic and continuous regulation of the pump (flow rate/head) depending on the actual requirements of the system, ensuring important energy savings.

APPLICATIONS

Ego circulators are specifically designed for heating systems and circulation of liquids in air-conditioning systems.

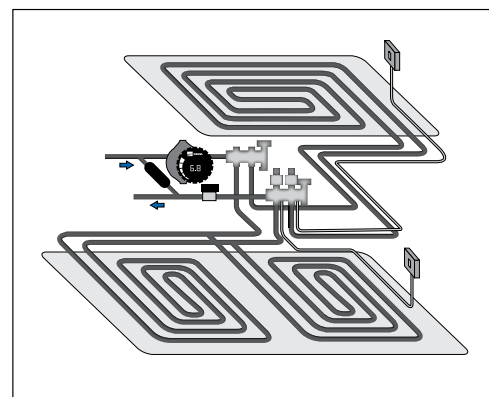
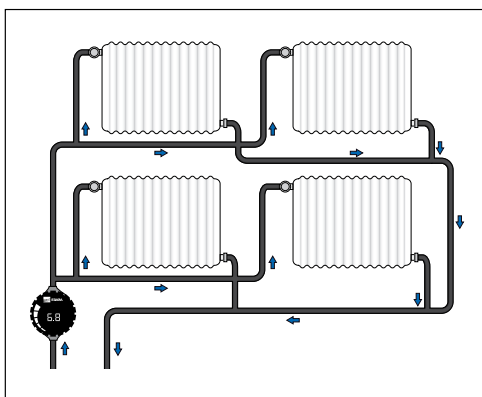
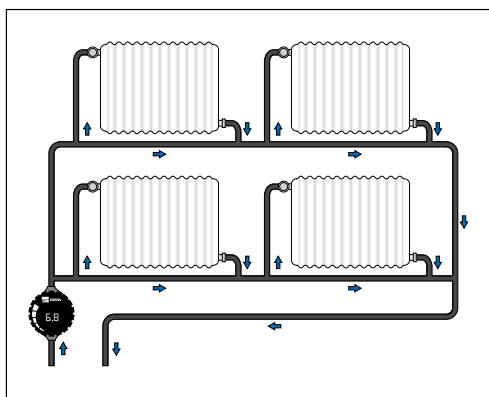

Heating systems

The pumps are suitable for single-pipe systems, two-pipe systems, underfloor heating systems and mixing loops of great installations. All Ego circulators automatically and autonomously control the differential pressure, adjusting pump performance in accordance with heating requirements.

Air-conditioning systems

Please refer to the minimum allowed temperatures of every product range to see how to use the Ego pumps. Some models are suitable for circulation at temperatures below 0°C (they are, therefore, particularly recommended for air-conditioning and/or refrigeration systems).

CONSTRUCTION

All Ego pumps are wet-rotor type; therefore, the pump and the motor make up a single unit with no mechanical seal; rotor bearings are lubricated directly by the pumped liquid. One of the most important features of Ego circulators is **the rotor can**, made of **a single part in AISI 316 stainless steel without welding points**: this solution, present on all Ego models, ensures hermetic, stable and reliable separation of the stator from the parts that come into contact with the liquid.

Other design features common to all Ego models are the following:

- Rotor in material resistant to corrosion
- Pump body in cathodolysis treated cast iron
- Low-friction bearings with consequent low noise emissions and reduced power consumption

For details on materials used please refer to the technical data sheets of every model.

PUMPED LIQUIDS

Ego circulators are suitable for the circulation of:

- clean, non-aggressive and non-explosive, free of solid particles or fibres (in compliance with VDI 2035)
- water/glycol mixtures

Liquid viscosity

During pump selection phase, one of the most important criteria is liquid viscosity that affects (reduces) the maximum performance of the circulator. In particular, **when using water/glycol mixtures with concentrations higher than 20%, the final viscosity should be verified carefully**, as it represents the criteria for selecting the most suitable circulator (contact our technical support centre for further information).

Hydraulic performance and all main technical data given in this catalogue refer to liquids with viscosity of 1mm²/s at 18°C.

Liquid and room temperature

Allowed fluid temperature range:

- | | |
|---|---------------------|
| • Mod. Ego small (mod. Ego -/40, -/60, -/80): | from +5 to +95 °C |
| • Mod. Ego medium (mod. Ego Easy -60, -80, -100): | from +2 to +110 °C |
| • Mod. Ego large (mod. Ego 40, 50, 65, 80, 100): | from -10 to +110 °C |

Room temperature allowed ranges from 0 to 40°C, with relative air humidity below 95%. In the event of use with fluids at low temperature, room temperature should always be lower than liquid temperature to prevent condensate from building up on stator casing.

Input pressure

In order to avoid noise, cavitation phenomena and damaging the bearing, it is essential to ensure a minimum pressure at suction inlet at all times (check the manuals of every model to see the minimum pressure values in relation to fluid temperature).

Maximum operating pressure

The maximum operating pressure for all **Ego models is 1 MPa (10 bar) – PN10**.

ASSEMBLY POSITION

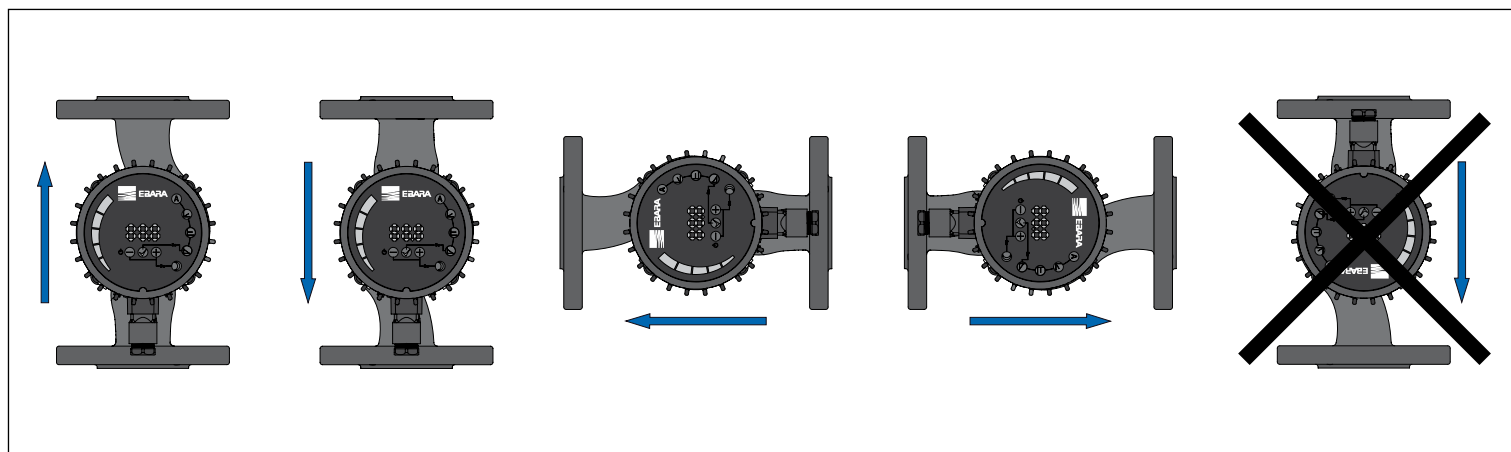

All Ego circulators should be installed with the **motor shaft in full horizontal position**, as shown in the figure above (example valid for all models). **The power cord should never be positioned upwards** (it may facilitate water inflow into the terminal box): in these cases, you should rotate the electronic unit or pump's body (please refer to the manual).



Ego

HIGH PERFORMANCE ELECTRONIC CIRCULATORS

in cast iron

ELECTRICAL FEATURES AND REGULATION

All Ego models are equipped with synchronous motor with rotor with permanent magnets and built-in frequency converter (ECM technology); **the electronic board measures the current consumption and calculates the instant pressure and flow rate to ensure continuous adjustment of hydraulic performance.** If the requested flow rate drops (usually when system valves close), the frequency converter automatically reduces the number of revolutions and, therefore, the power consumption. Variations may reach to 1/5 of maximum pump capacity.

Therefore, this technology ensures:

- **Continuous adjustment of performance in accordance with the actual requirements of the system**
- **High efficiency**
- **Great starting torque (automatic release even after long periods of inactivity)**
- **Complete motor protection**

Supplied voltage

The supplied voltage for all Ego models is **1~230V - 50/60 Hz**

Control modes

The built-in electronic board enables, depending on the model, various control modes such as:

- **Automatic regulation**
- **ΔP -v Proportional pressure**
- **ΔP -c Constant pressure**
- **Constant speed**
- **Current limit control**
- **Power limit control**

(Please refer to the data sheets of every model to check the available control modes).

CONNECTIONS AND REMOTE CONTROL

Depending on the models, the following additional connections are available:

a) Analog external regulation (contact 0-10V)

The external contact 0-10V can be used in various modes:

- in "constant speed" regulation mode, the external contact 0-10V enables switching from a constant curve to another, according to the value of the input signal.
- in "proportional pressure" regulation mode, the external contact 0-10V enables switching from a variable curve to another, according to the value of the input signal.

With signals below 1V, the circulator enters stand-by mode.

b) Control from PC (Ethernet connection)

Some Ego models can be fully programmed and controlled remotely via the PC, using an Ethernet connection. The connections modes are 2:

- **Direct connection** "circulator – PC" (with CROSS-OVER type cable) - **Fig. 1**
- **Network connection** via router (with PATCH cable) - **Fig. 2**



Once you have completed the Ethernet connection, you can access the circulator using any internet browser (Chrome, Internet Explorer, Firefox, etc.) typing in the IP address of the pump, indicated in the manual. Once you have completed the connection to the PC, various video pages enable you to fully program the circulator, the digital inputs, the relays etc. and also to display the instant operating parameters, the power consumption and the errors.

c) Remote control via Modbus

Some models include an RS-485 connection for communication via **Modbus RTU** protocol.

d) Digital inputs and output relays

Some models are equipped with digital inputs and output relays for:

- Switch-on and remote regulation
- Tandem operation (twin)
- Stand-by signals, operation, errors etc.



Ego

HIGH PERFORMANCE ELECTRONIC CIRCULATORS

in cast iron

ENERGY LABEL

All Ego models comply with European Directive EuP (Energy Using Products) / ErP (Energy Related Products). The Regulation CE 641/2009 and subsequent amendments CE 622/2012 implement this directive by defining specific Eco-design parameters. With regard to wet-rotor circulators, **the reference parameter is the EEI index (Energy Efficiency Index)**, that identifies the total performance of the pump on a decreasing gradient (or, to the lowest EEI values corresponds a better pump performance).

The due dates provided by the Directive are the following:

- **1st step:** starting from **01/01/2013** are allowed only circulators with **EEI ≤ 0,27**
- **2nd step:** starting from **01/08/2015** are allowed only circulators with **EEI ≤ 0.23**

Exemptions

The application does not include the energy efficiency requirements (EEI index) until 01/08/2015 the **built-in circulators**” (or those specifically designed to be incorporated in machines) and those specifically designed **for solar systems and domestic hot water systems**.

The technical data sheets of the products indicate the EEI index for every model (value also specified on product nameplate in compliance with specific regulations).

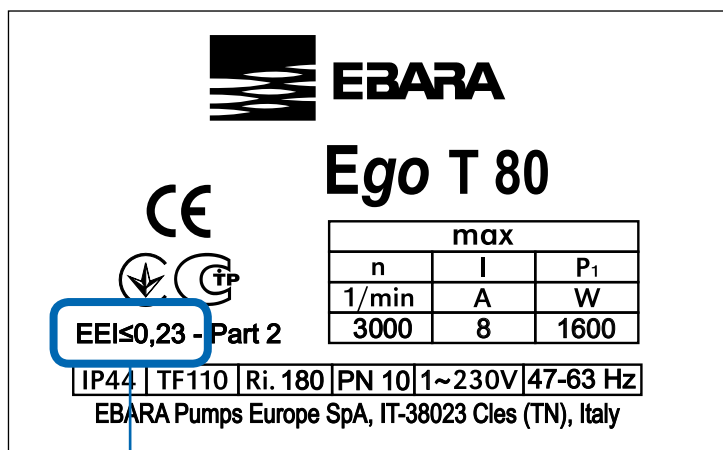

EXAMPLE OF NAMEPLATE WITH EEI INDEX

The content of this publication should not be considered mandatory. EBARA Pumps Europe S.p.A. reserves the right to change the content without prior notice.

CONTROL MODE

Below are described all control modes available within the Ego range. Depending on the model, control modes may be available entirely or partly. Therefore, please refer to the data sheets of every model to check the available control modes.

a) AUTO (factory setting, where provided)

In this mode **the pump automatically adjusts hydraulic performance** according to the actual requirements of the system, measuring the optimal H/Q point permanently. The AUTO mode is a form of proportional pressure regulation in which the curves have a fixed origin (H_{min}); the circulator will work according to system requirements in any point of the area highlighted in the figure, where both H_{min} and H_{max1} as well as H_{max2} are factory settings. **This operating mode is suitable for most applications and ensures high energy savings.**

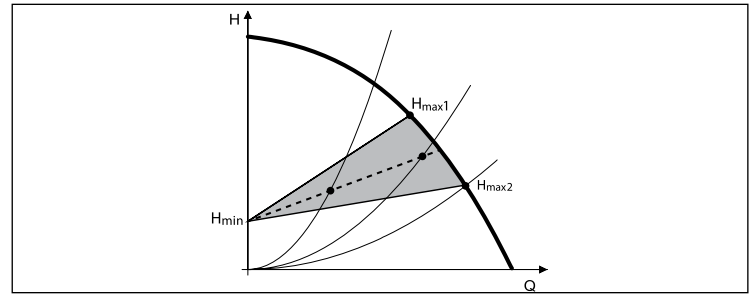

b) Proportional pressure ($\Delta p-v$)

In this mode, the pump automatically adjusts the pressure depending on the flow rate requested by the system, varying it linearly from a minimum to a maximum value. In practice: **when the flow rate requested increases, the differential pressure** generated by the pump is increased as well, and vice versa. This adjustment is **recommended for systems with high pressure drops**. For smaller models, the work curves ($H_{min}-H_{max}$) are preset, while for greater models they can be set within a wide range.

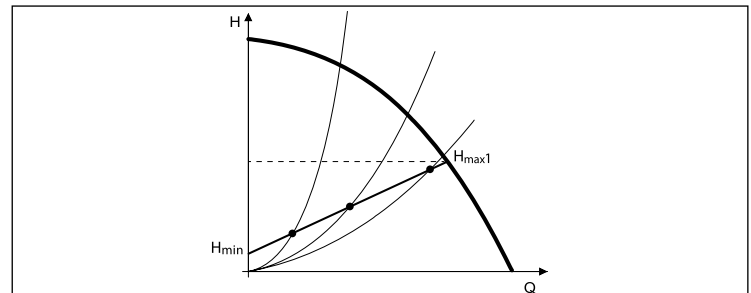

c) Constant pressure ($\Delta P-c$)

In this mode **the pump head is maintained constant** (equal to the value set by the user) **regardless of the flow rate**. This mode, **recommended in systems with reduced pressure drops**, is available starting from medium sizes and enables selecting the desired pressure H_{set} (in metres) within a wide range.

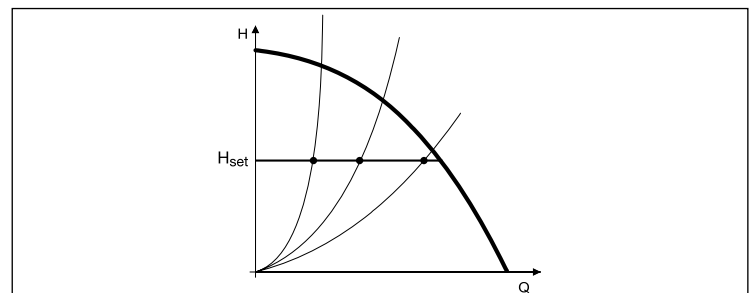

d) Constant speed

In this mode **the pump works according to a steady curve** like a common pump without regulation.

You can set various speeds or different constant work curves. In smaller models, the available curves are preset, while in greater models they can be set within a wide range (by setting the desired rotation speed in rpm).

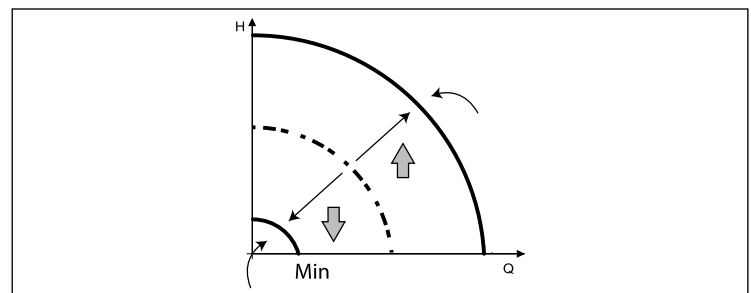

PERFORMANCE RANGE

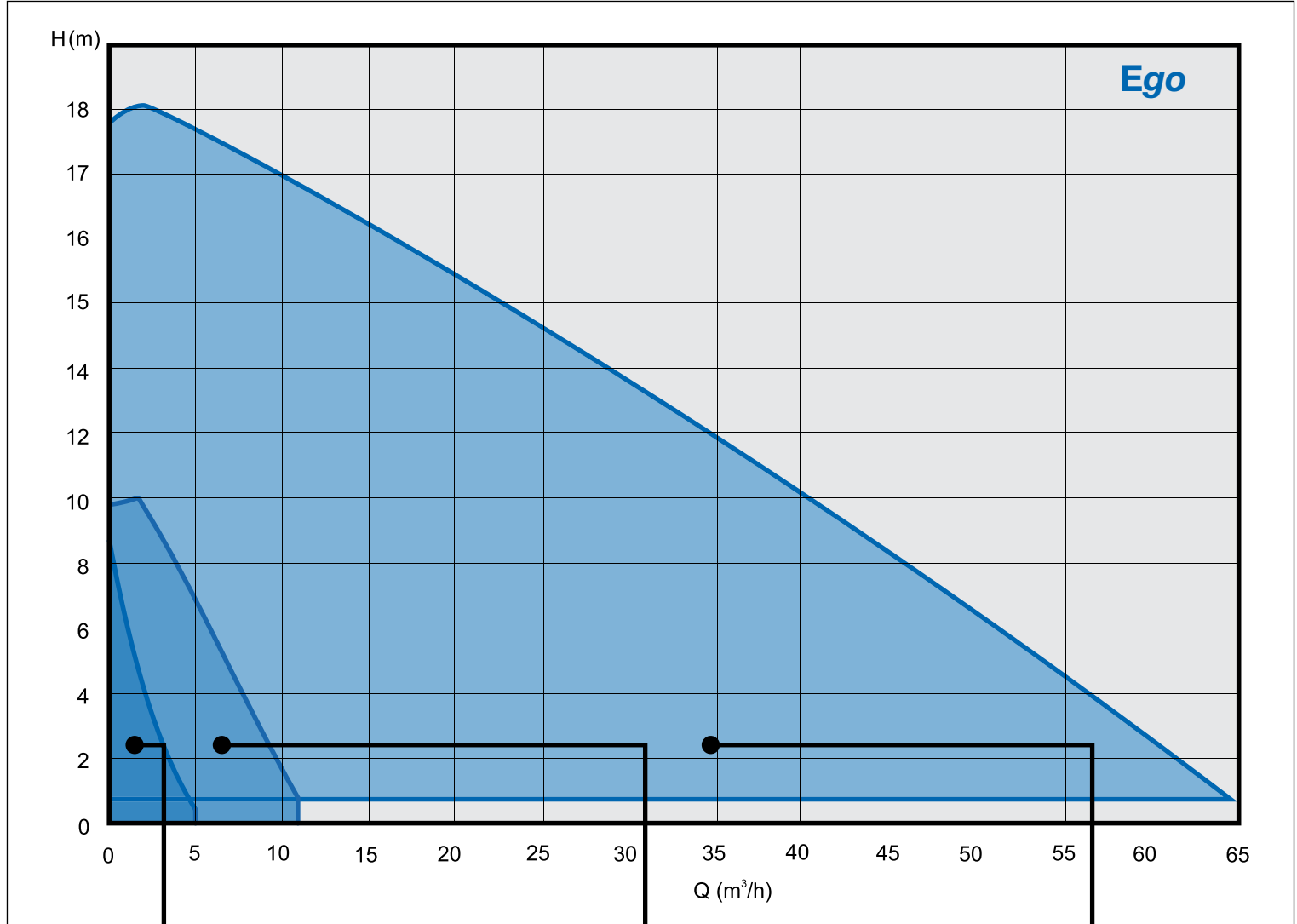

THREADED CIRCULATORS
Ego (T) (ER) -/40, -/60, -/80



THREADED/FLANGED CIRCULATORS
Ego easy (T) (C) -60, -80, -100



FLANGED CIRCULATORS
Ego (T) (C) 40, 50, 65, 80, 100

Ego

THREADED CIRCULATORS

Ego (T) (ER) -/40, -/60, -/80, single and twin



High performance wet-rotor circulation pump with threaded connection, motor with permanent magnets and built-in electronic controller.

APPLICATIONS

Residential heating and air-conditioning systems.

FEATURES

- Minimum power consumption only 5W
- Built-in frequency converter
- Two operating modes ("ΔP-v" and "constant speed")
- Automatic venting function
- High input torque (with consequent automatic release of the rotor)
- Easy installation and adjustment by means of a single LED button
- 0-10V contact (optional, see versions "ER")

PUMP TECHNICAL DATA

- Liquid temperature: +5 ÷ +95 °C
- Room temperature: 0 ÷ +40 °C
- Relative air humidity: ≤ 95%
- Allowed fluids: clean, non aggressive and not flammable, free of solid particles or fibres
- Maximum pressure: 10 bar
- Minimum suction pressure:
 - 0,05 bar at 50 °C
 - 0,4 bar at 80 °C
 - 1,1 bar at 110 °C
- Maximum amount of glycol: 20%*
- Threaded inlets: G 1" – 1 1/2" – 2" (in accordance with ISO 228)
- Protection degree: IP44

MOTOR TECHNICAL DATA

- Type: synchronous with permanent magnets
- Motor speed: variable
- Supply voltage: 1~230V
- Frequency: 50/60 Hz
- Insulation class: F

* For greater amounts please check the final viscosity and the conditions of use.

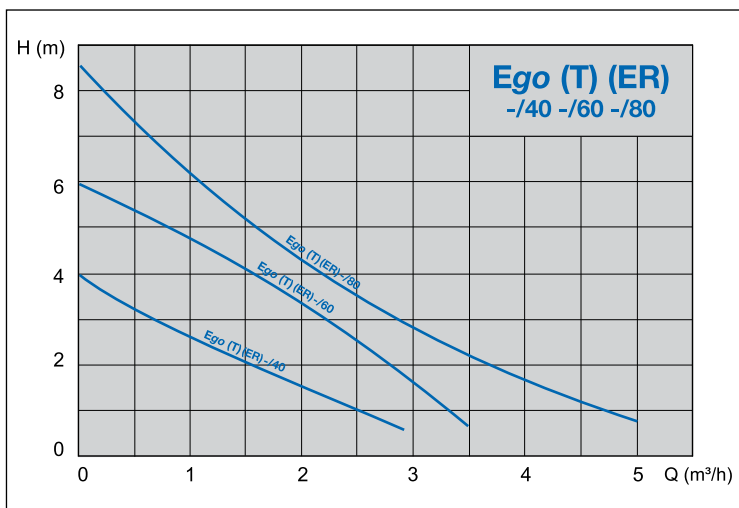

IDENTIFICATION CODE

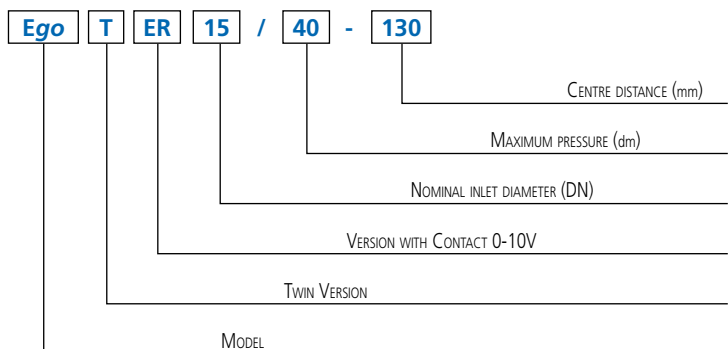

THREADED CIRCULATORS

Ego (T) (ER) -/40, -/60, -/80, single and twin

OPERATING MODES

Two operating modes that can be selected using the LED button located on terminal box:

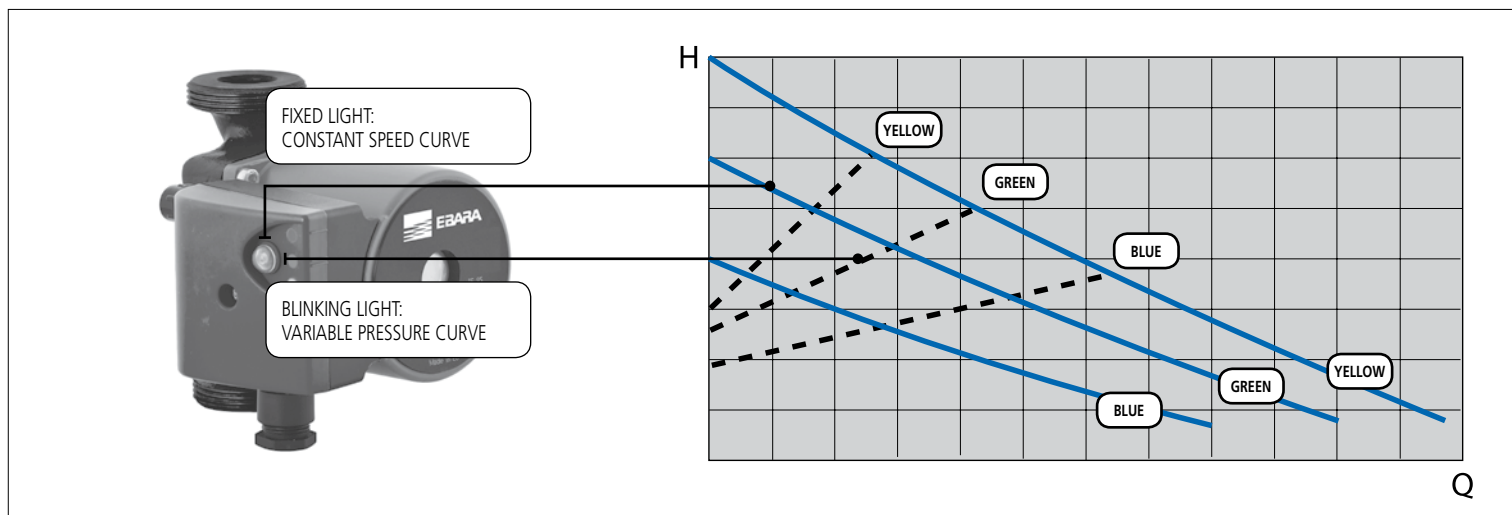

• ΔP -v Proportional pressure (factory setting)

The circulators of this range can work in variable pressure **mode on 3 preset curves**. When this operating mode is enabled **the LED button blinks**, with a frequency that varies according to instant flow rate. **The colour of the LED identifies the selected curve** ("blue" indicates the lowest curve, "green" the intermediate curve, while "yellow" indicates the highest curve); to switch from one curve to another just press the button briefly.

From variable pressure modes (LED blinking) you can switch to constant speed mode (LED light steadily lit) keeping the LED button pressed for at least 5 seconds.

• Constant speed

The circulators of this range can work at constant speed **on 3 preset curves**. In this case, the pump works as a usual pump without regulation and the power consumption remains constant. When this mode is active **the LED remains steadily lit**; in this case the colour of the LED **indicates the selected curve** ("blue" the lowest curve, "green" the intermediate curve, and "yellow" the highest curve). To switch from one curve to another, briefly press the button to return to variable pressure mode, select the desired curve (indicated by the colour of the LED) and then press and hold down the button.

VERSIONS WITH ANALOG REGULATION 0-10V (mod. Ego ER -/40, -/60, -/80)

The special versions **Ego ER**, equipped with 0-10V contact inside the terminal box, enable setting the desired work curve remotely (both the fixed speed and the variable differential pressure). In this case, as shown in the diagrams below, the work curves are more numerous.

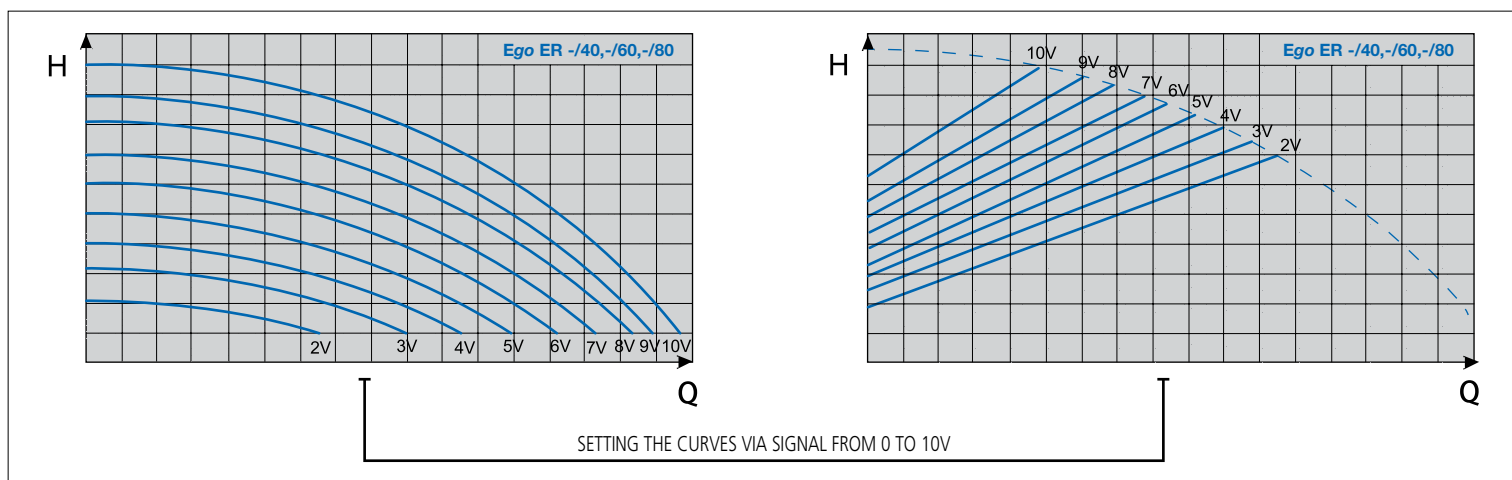



Ego

THREADED CIRCULATORS

Ego (T) (ER) -/40, -/60, -/80, single and twin

PERFORMANCE CURVES

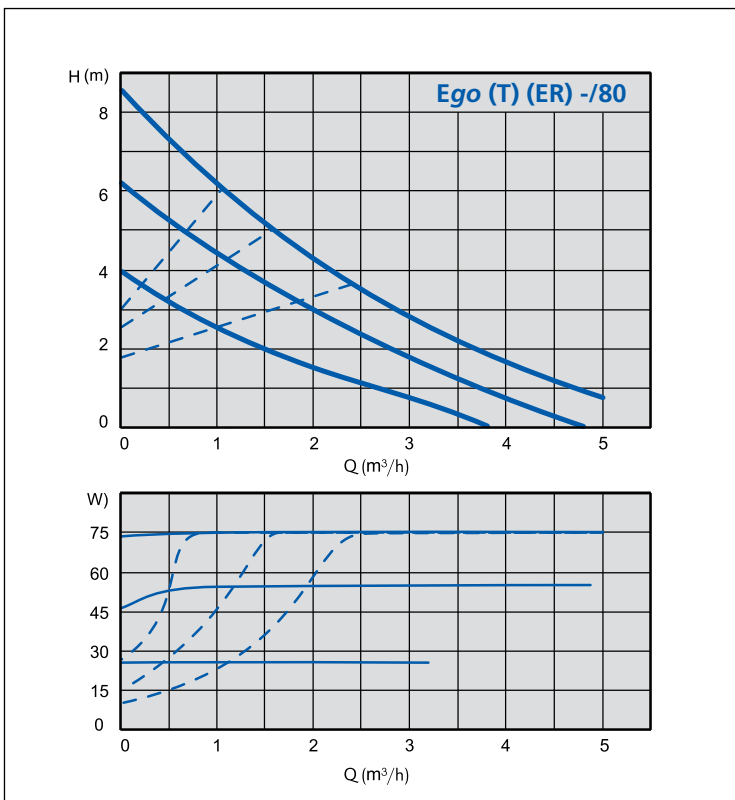
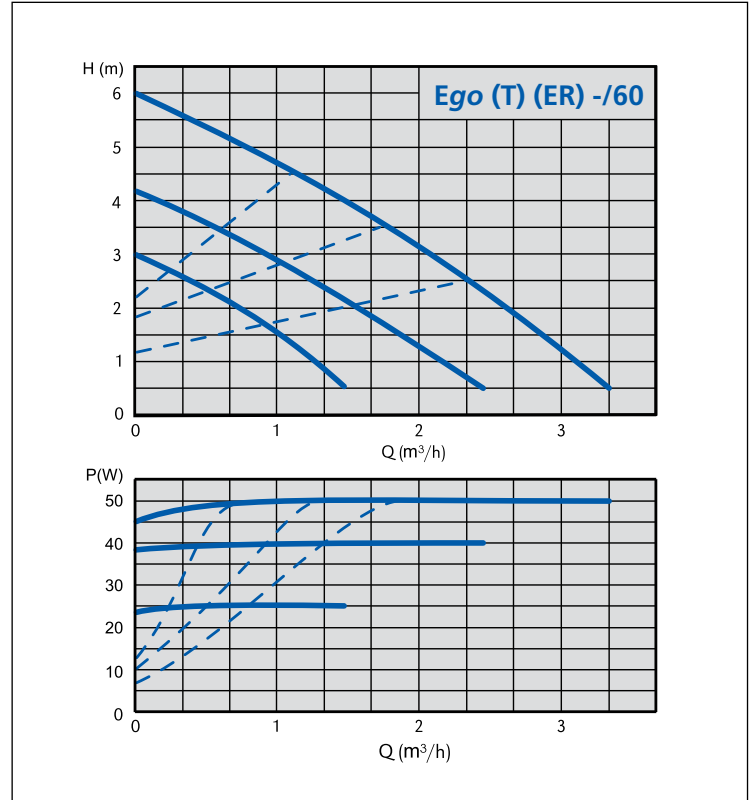
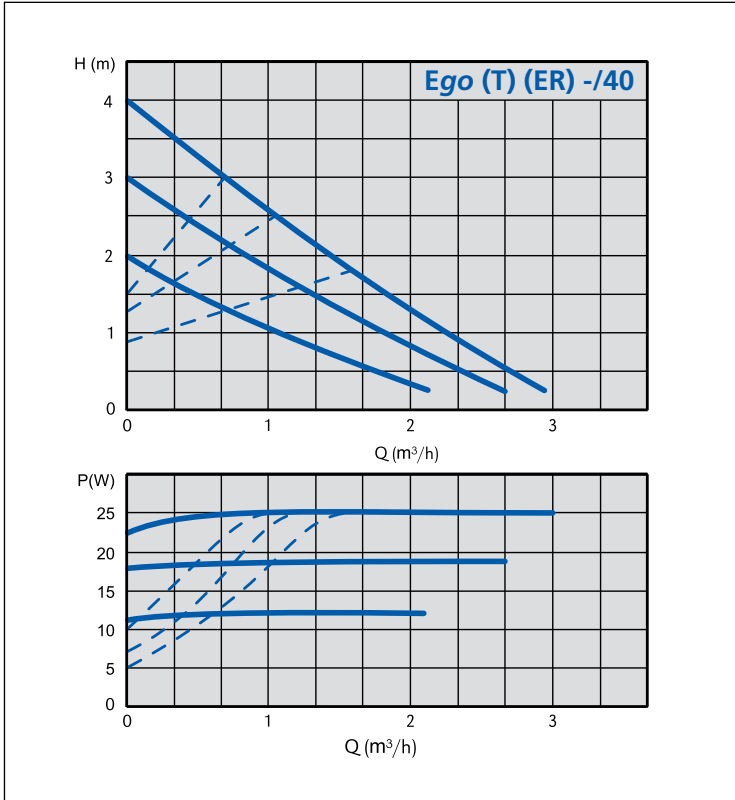

The content of this publication should not be considered mandatory. EBARA Pumps Europe S.p.A. reserves the right to change the content without prior notice.

THREADED CIRCULATORS

Ego (T) (ER) -/40, -/60, -/80, single and twin

SECTIONAL VIEW

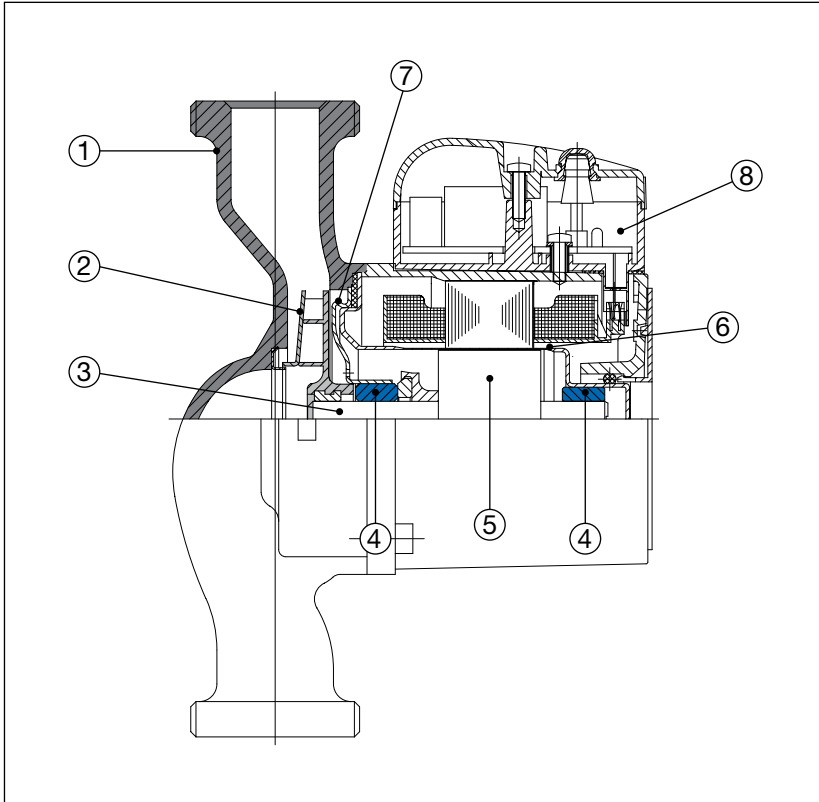

TABLE OF MATERIALS

| Ref. | Part | Material |
|------|------------------|---------------------------|
| 1 | Pump body | Cast iron |
| 2 | Impeller | Technopolymer |
| 3 | Shaft | Ceramic |
| 4 | Bearings | Ceramic |
| 5 | Rotor | Coated in Stainless Steel |
| 6 | Rotor can | AISI 316 Stainless Steel |
| 7 | Bearing plate | AISI 316 Stainless Steel |
| 8 | Electronic board | - |

TECHNICAL FEATURES - single

| Model | EEl (energy efficiency index) | Pipe connection | Inlet fitting | Power P ₁ [W] P _{min} - P _{max} | Current consumption [A] I _{min} - I _{max} | Weight [kg] |
|--------------------|----------------------------------|-----------------|---------------|---|--|-------------|
| Ego (ER) 15/40-130 | ≤ 0,20 | G1" | Rp ½" | 5 ÷ 25 | 0,05 ÷ 0,2 | 1,9 |
| Ego (ER) 25/40-130 | ≤ 0,20 | G1"½" | Rp 1" | 5 ÷ 25 | 0,05 ÷ 0,2 | 2,1 |
| Ego (ER) 15/60-130 | ≤ 0,22 | G1" | Rp ½" | 7 ÷ 50 | 0,05 ÷ 0,4 | 1,9 |
| Ego (ER) 25/60-130 | ≤ 0,22 | G1"½" | Rp 1" | 7 ÷ 50 | 0,05 ÷ 0,4 | 2,1 |
| Ego (ER) 25/80-130 | ≤ 0,24 | G1"½" | Rp 1" | 7 ÷ 75 | 0,05 ÷ 0,6 | 2,1 |
| Ego (ER) 25/40-180 | ≤ 0,20 | G1"½" | Rp 1" | 5 ÷ 25 | 0,05 ÷ 0,2 | 2,4 |
| Ego (ER) 32/40-180 | ≤ 0,20 | G2" | Rp 1"¼" | 5 ÷ 25 | 0,05 ÷ 0,2 | 2,5 |
| Ego (ER) 25/60-180 | ≤ 0,22 | G1"½" | Rp 1" | 7 ÷ 50 | 0,05 ÷ 0,4 | 2,4 |
| Ego (ER) 32/60-180 | ≤ 0,22 | G2" | Rp 1"¼" | 7 ÷ 50 | 0,05 ÷ 0,4 | 2,5 |
| Ego (ER) 25/80-180 | ≤ 0,24 | G1"½" | Rp 1" | 7 ÷ 75 | 0,05 ÷ 0,6 | 2,4 |
| Ego (ER) 32/80-180 | ≤ 0,24 | G2" | Rp 1"¼" | 7 ÷ 75 | 0,05 ÷ 0,6 | 2,5 |

TECHNICAL FEATURES - twin

| Model | EEl (energy efficiency index) | Pipe connection | Inlet fitting | Power P ₁ [W] P _{min} - P _{max} | Current consumption [A] I _{min} - I _{max} | Weight [kg] |
|-----------------|----------------------------------|-----------------|---------------|---|--|-------------|
| Ego T 25/60-180 | ≤ 0,22 | G1"½" | Rp 1" | 7 ÷ 50 | 0,05 ÷ 0,4 | 5,5 |
| Ego T 32/60-180 | ≤ 0,22 | G2" | Rp 1"¼" | 7 ÷ 50 | 0,05 ÷ 0,4 | 5,5 |
| Ego T 25/80-180 | ≤ 0,24 | G1"½" | Rp 1" | 7 ÷ 75 | 0,05 ÷ 0,6 | 5,7 |
| Ego T 32/80-180 | ≤ 0,24 | G2" | Rp 1"¼" | 7 ÷ 75 | 0,05 ÷ 0,6 | 5,7 |

Ego

THREADED CIRCULATORS

Ego -/40, -/60, -/80

DIMENSIONS - single

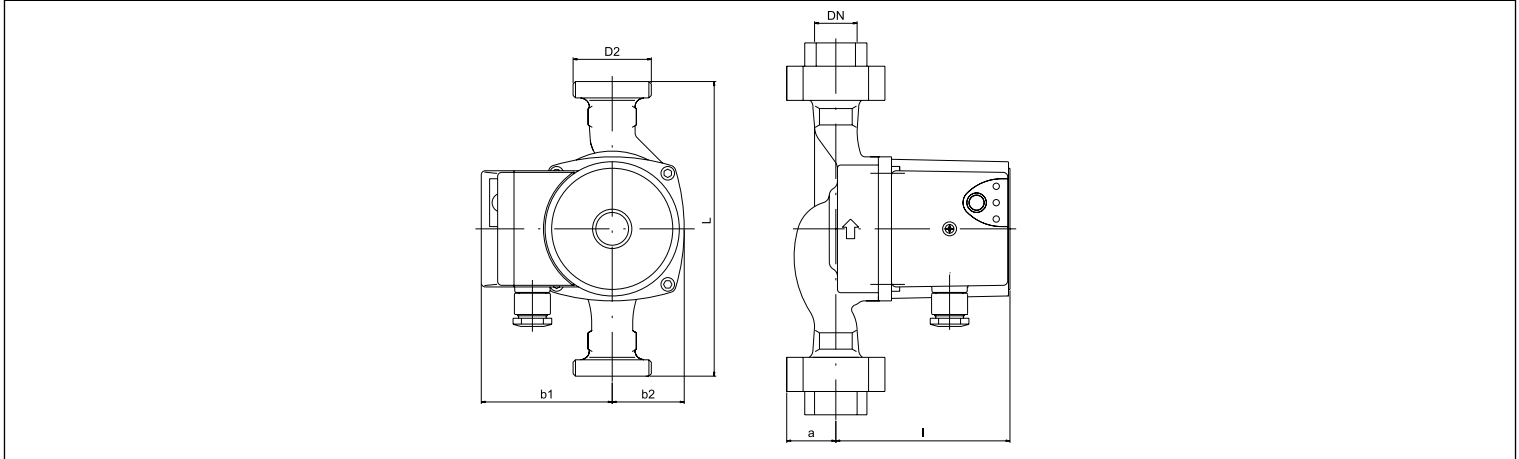
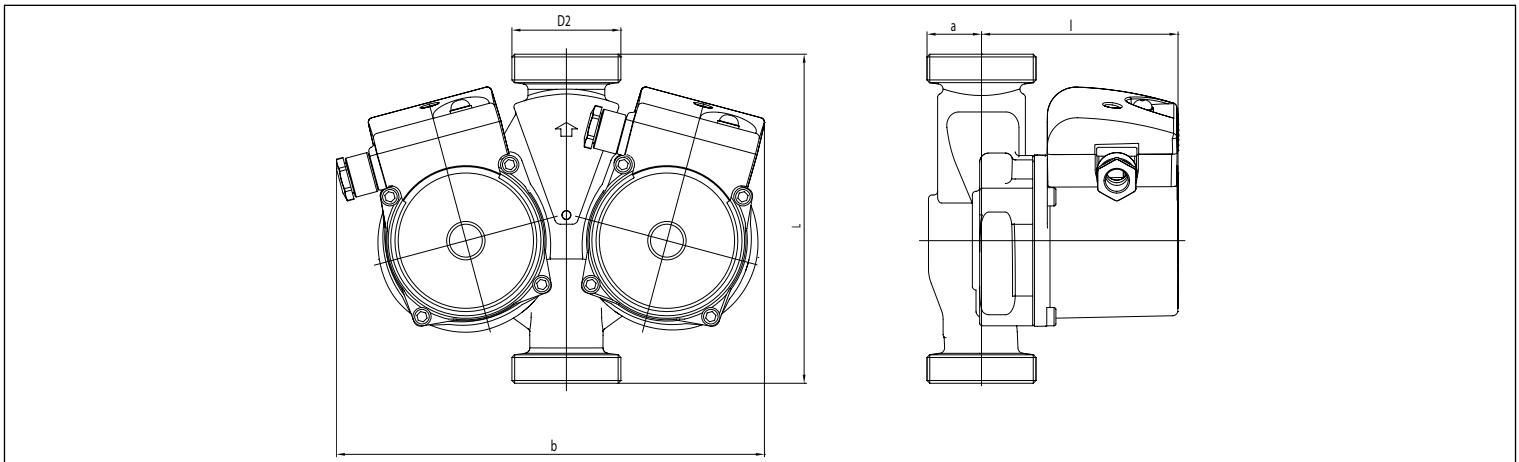

TABLE OF DIMENSIONS - single

| Model | Dimensions [mm] | | | | | | |
|--------------------|-----------------|----|----|----|-----|----|-----|
| | L | DN | b1 | b2 | l | a | D2 |
| Ego (ER) 15/40-130 | 130 | 15 | 80 | 48 | 108 | 27 | 1" |
| Ego (ER) 25/40-130 | 130 | 25 | 80 | 48 | 108 | 32 | 1"½ |
| Ego (ER) 15/60-130 | 130 | 15 | 80 | 48 | 108 | 27 | 1" |
| Ego (ER) 25/60-130 | 130 | 25 | 80 | 48 | 108 | 32 | 1"½ |
| Ego (ER) 25/80-130 | 130 | 25 | 80 | 48 | 108 | 32 | 1"½ |
| Ego (ER) 25/40-180 | 180 | 25 | 80 | 48 | 108 | 32 | 1"½ |
| Ego (ER) 32/40-180 | 180 | 32 | 80 | 48 | 108 | 40 | 2" |
| Ego (ER) 25/60-180 | 180 | 25 | 80 | 48 | 108 | 32 | 1"½ |
| Ego (ER) 32/60-180 | 180 | 32 | 80 | 48 | 108 | 40 | 2" |
| Ego (ER) 25/80-180 | 180 | 25 | 80 | 48 | 108 | 32 | 1"½ |
| Ego (ER) 32/80-180 | 180 | 32 | 80 | 48 | 108 | 40 | 2" |

DIMENSIONS - twin



DIMENSIONS - twin

| Model | Dimensions [mm] | | | | | | |
|-----------------|-----------------|----|-----|-------|------|-----|--|
| | L | DN | b | l | a | D2 | |
| Ego T 25/80-180 | 180 | 25 | 234 | 107,2 | 29,8 | 1"½ | |
| Ego T 32/80-180 | 180 | 32 | 234 | 107,2 | 29,8 | 2" | |
| Ego T 25/60-180 | 180 | 25 | 234 | 107,2 | 29,8 | 1"½ | |
| Ego T 32/60-180 | 180 | 32 | 234 | 107,2 | 29,8 | 2" | |

Ego

THREADED CIRCULATORS

Ego -/40, -/60, -/80

ASSEMBLY POSITION

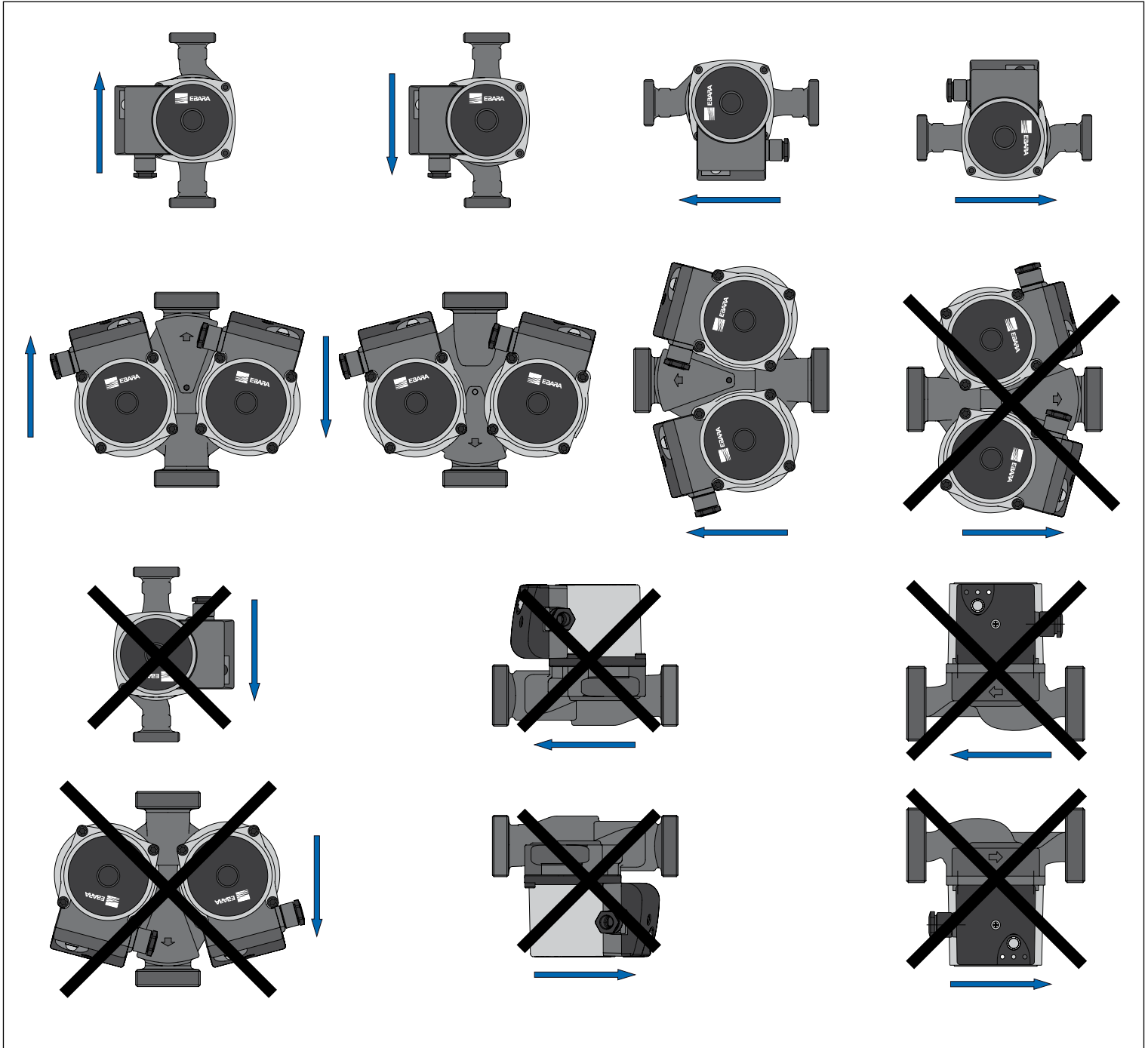

THREADED/FLANGED CIRCULATORS

Ego (T) (C) easy -60, -80, -100 single and twin



High performance wet rotor circulation pump with threaded or flanged connection, motor with permanent magnets and built-in electronic controller.

APPLICATION

Residential and industrial heating and air-conditioning systems.

FEATURES

- Built-in frequency converter
- Multiple operating modes
- Numeric and graphical display for easy setup and visualisation of parameters
- Automatic venting function
- Built-in overload safety device
- High input torque (with consequent automatic release of the rotor)
- Optional communication module (with Ethernet port, 0-10V contact, digital inputs etc.)

PUMP TECHNICAL DATA

- Liquid temperature: $+2 \div +110 \text{ }^\circ\text{C}$
- Room temperature: $0 \div +40 \text{ }^\circ\text{C}$
- Relative air humidity: $\leq 95\%$
- Allowed fluids: clean, non aggressive and not flammable, free of solid particles or fibres
- Maximum pressure: 10 bar
- Minimum suction pressure:
 - 0,05 bar to $50 \text{ }^\circ\text{C}$
 - 0,8 bar to $80 \text{ }^\circ\text{C}$
 - 1,4 bar to $110 \text{ }^\circ\text{C}$
- Maximum amount of glycol: 20%*
- Threaded inlets: G 1 1/2" – 2" (in accordance with ISO 228)
- Flanged inlets: from DN 32 to DN 50
- Protection degree: IP44

MOTOR TECHNICAL DATA

- Type: synchronous with permanent magnets
- Motor speed: variable
- Supply voltage: 1~230V
- Frequency: 50/60 Hz
- Insulation class: F

* For greater amounts please check the final viscosity and the conditions of use.

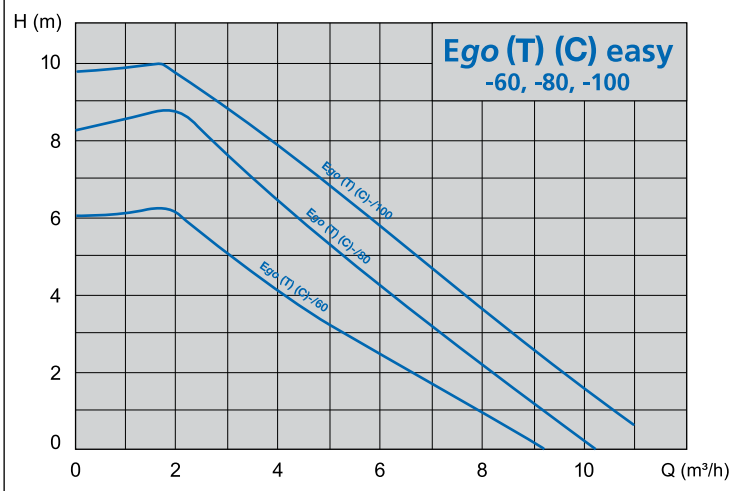

INITIALS

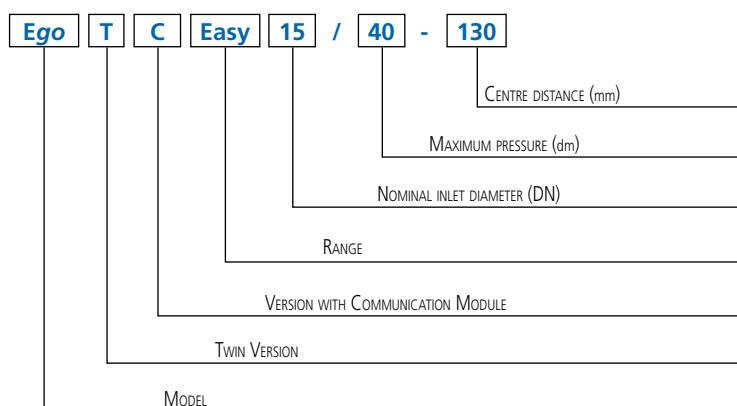

THREADED/FLANGED CIRCULATORS

Ego (T) (C) easy -60, -80, -100 single and twin

OPERATING MODES

The operating modes can be selected using the buttons located on the rear panel:

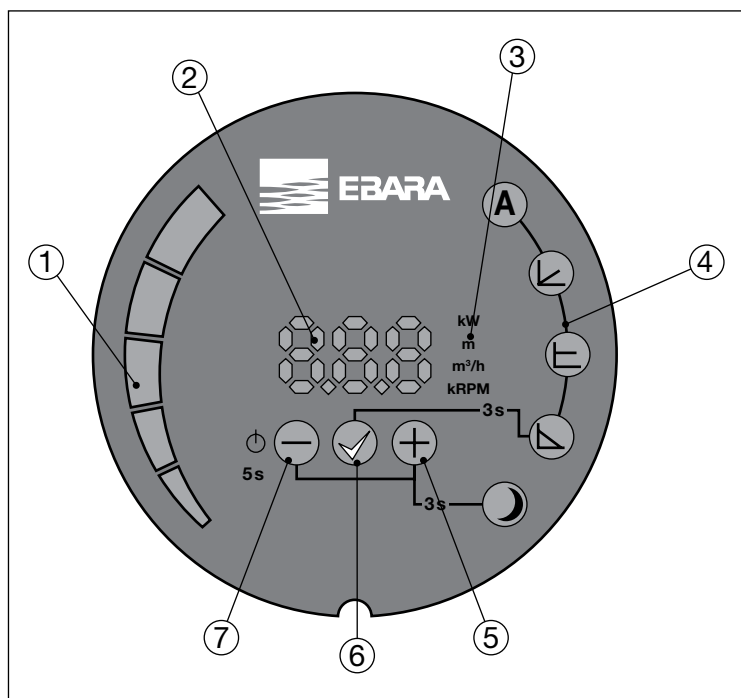

KEY

- 1 Segment display
- 2 Numeric display
- 3 Display of selected parameter
- 4 Display of selected mode
- 5 Selection key
- 6 Confirmation key
- 7 Selection key

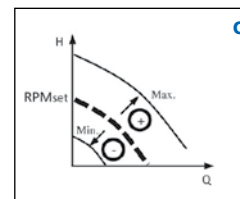
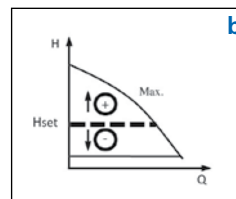
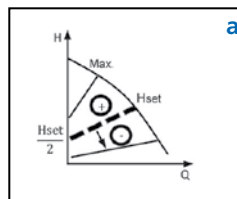

A AUTO mode (factory setting)
The circulator automatically adjusts the hydraulic performance depending on the actual requirements of the system, continuously measuring the optimal H/Q point. This operating mode is suitable for most applications and ensures high energy savings.

Proportional pressure ($\Delta P-v$) - fig. a
The circulator adjusts the pump head depending on the flow rate, varying the latter linearly from a maximum value (H_{set}) to a minimum value (equal to $H_{set}/2$). The pressure value (H_{set}) is set via buttons \oplus and \ominus and is expressed in metres; the minimum value is automatically calculated by the circulator.

Constant pressure ($\Delta P-c$) - fig. b
The circulator maintains the pump head constant when the flow rates varies. The value of the pressure (H_{set}) is set via buttons \oplus and \ominus and is expressed in metres.

Constant speed - fig. c
The circulator operates according to a constant curve set via buttons \oplus and \ominus (by selecting the rotation speed in "rpm").

Night mode
Night mode can be activated in combination with any of the operating modes listed above, and allows the circulator to operate at a minimum curve (therefore with very low consumption) when it detects a decrease in liquid temperature of 15-20 °C. When temperature rises, it automatically returns to normal operating curve (according to the selected mode).

THREADED/FLANGED CIRCULATORS

Ego (T) (C) easy -60, -80, -100 single and twin

COMMUNICATION MODULE (versions "Ego easy C")

Versions **Ego easy C** are equipped with an additional communication module which can be accessed by opening the rear display panel. The communication module is also available as an optional accessory. It is compatible with all standard models Ego easy. The module enables running a wide range of applications remotely:

- Access via Ethernet
- Remote On/Off
- Analog control 0-10V
- Modbus RTU
- Alarm/state relay

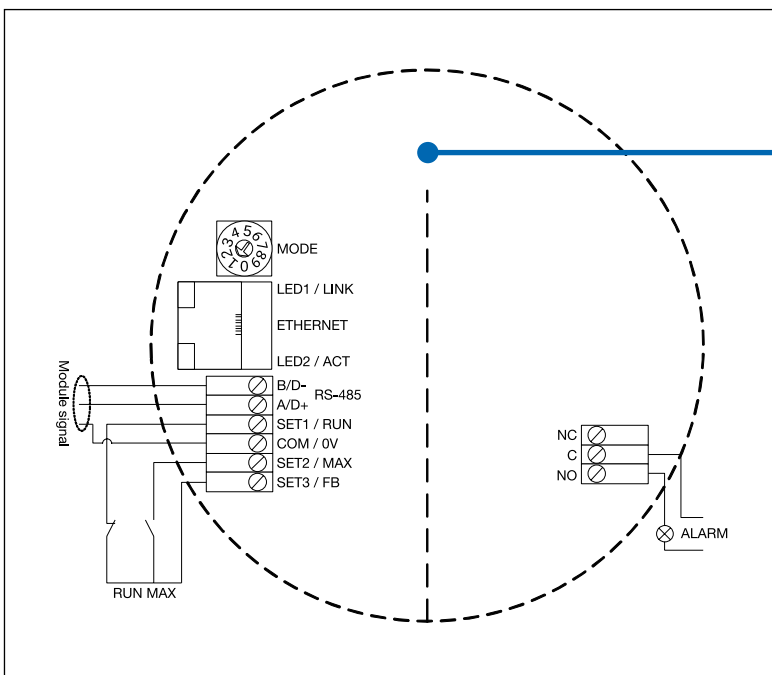
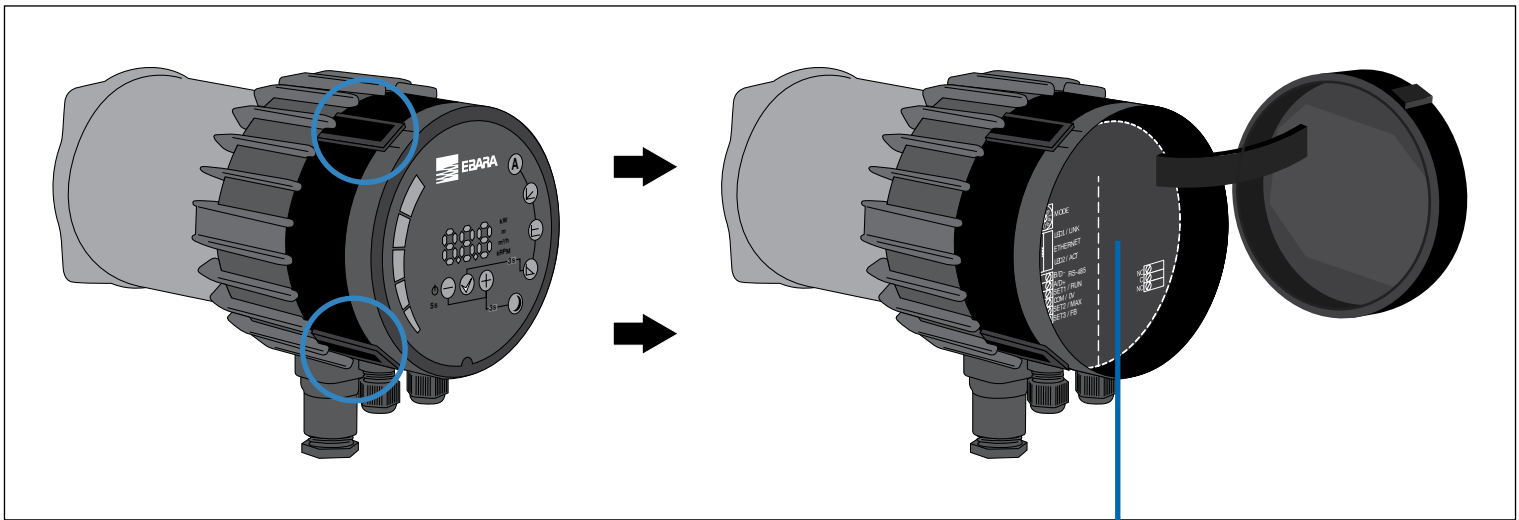

THREADED/FLANGED CIRCULATORS

Ego (T) (C) easy -60, -80, -100 single and twin

PERFORMANCE CURVES

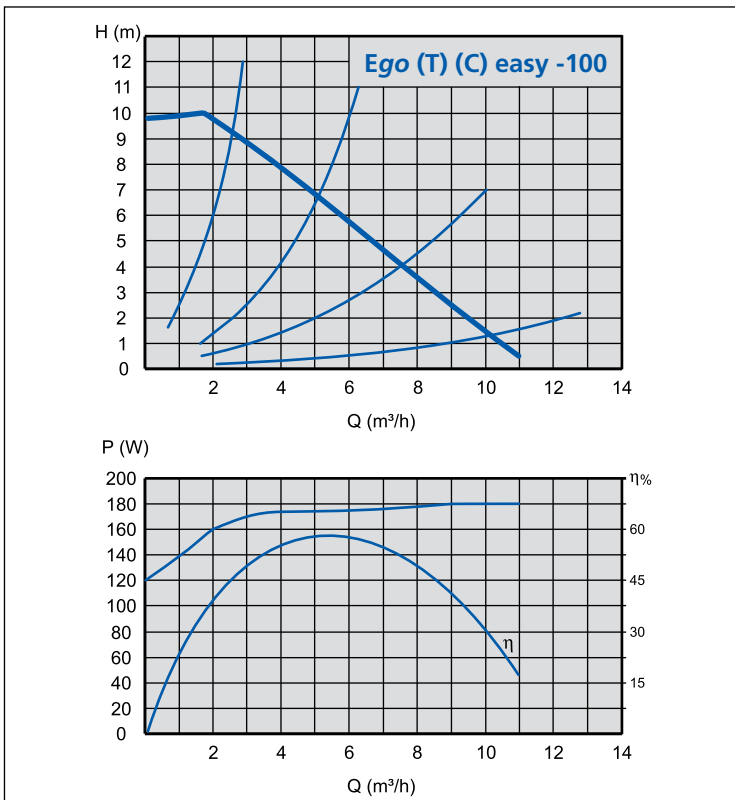
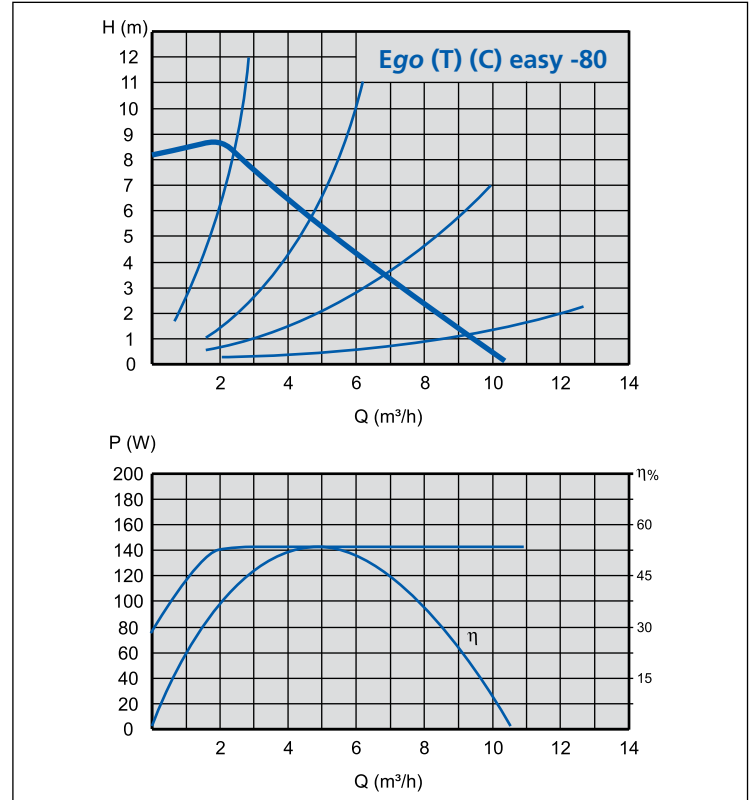
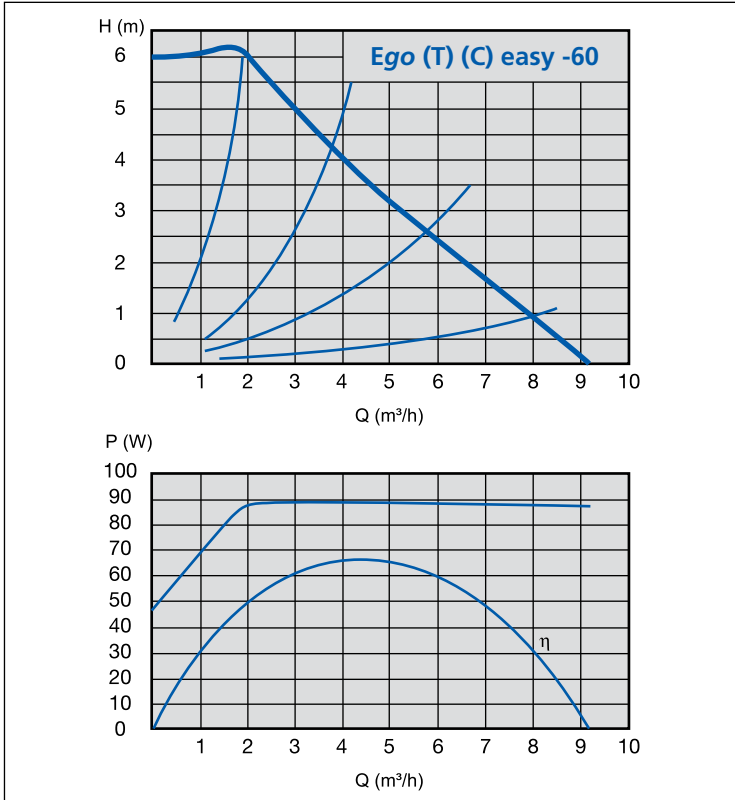

THREADED/FLANGED CIRCULATORS

Ego (T) (C) easy -60, -80, -100 single and twin

SECTIONAL VIEW

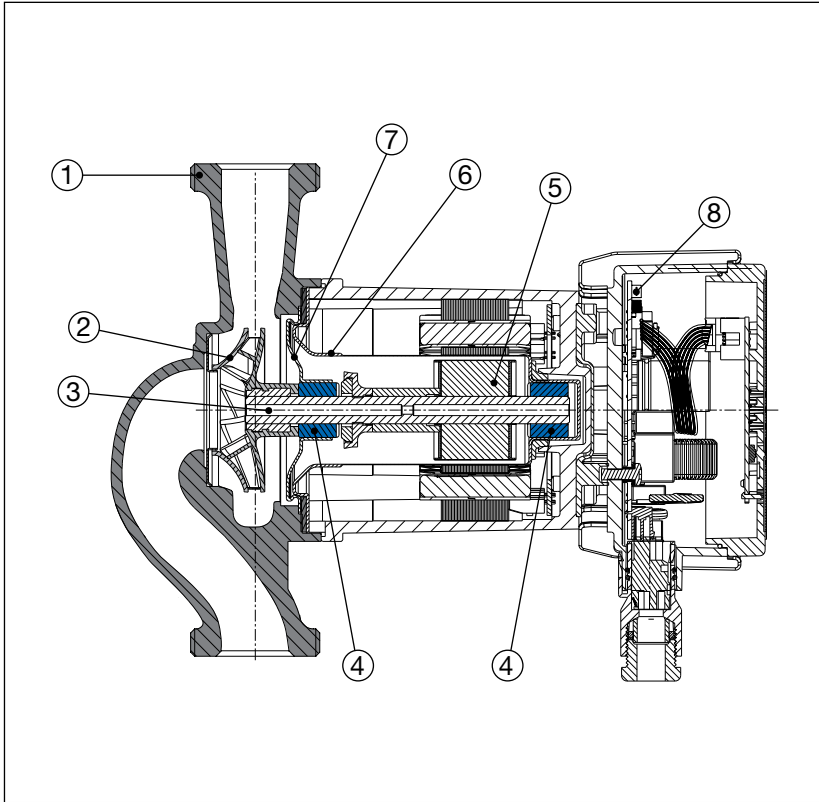

TABLE OF MATERIALS

| Ref. | Part | Material |
|------|------------------|---------------------------|
| 1 | Pump body | Cast iron |
| 2 | Impeller | Technopolymer |
| 3 | Shaft | Stainless steel |
| 4 | Bearings | Graphite |
| 5 | Rotor | Coated in stainless steel |
| 6 | Rotor can | AISI 316 Stainless Steel |
| 7 | Bearing plate | AISI 316 Stainless Steel |
| 8 | Electronic board | - |

TECHNICAL FEATURES - single

| Model | EEl (energy efficiency index) | Pipe connection | Inlet fitting | Power P_1 [W] $P_{min} - P_{max}$ | Current consumption [A] $I_{min} - I_{max}$ | Weight [kg] |
|------------------|-------------------------------|-----------------|---------------|--|--|-------------|
| Ego easy 25-60 | $\leq 0,21$ | G1"½ | Rp 1" | 10 ÷ 90 | 0,1 ÷ 0,75 | 4,0 |
| Ego easy 32-60 | $\leq 0,21$ | G2" | Rp 1"¼ | 10 ÷ 90 | 0,1 ÷ 0,75 | 4,1 |
| Ego easy 25-80 | $\leq 0,21$ | G1"½ | Rp 1" | 10 ÷ 140 | 0,1 ÷ 1,15 | 4,0 |
| Ego easy 32-80 | $\leq 0,21$ | G2" | Rp 1"¼ | 10 ÷ 140 | 0,1 ÷ 1,15 | 4,1 |
| Ego easy 25-100 | $\leq 0,21$ | G1"½ | Rp 1" | 10 ÷ 180 | 0,1 ÷ 1,5 | 4,0 |
| Ego easy 32-100 | $\leq 0,21$ | G2" | Rp 1"¼ | 10 ÷ 180 | 0,1 ÷ 1,5 | 4,1 |
| Ego easy 32-100F | $\leq 0,21$ | DN 32 (flanged) | - | 10 ÷ 180 | 0,1 ÷ 1,5 | 7,4 |
| Ego easy 40-100F | $\leq 0,21$ | DN 40 (flanged) | - | 10 ÷ 180 | 0,1 ÷ 1,5 | 8,5 |
| Ego easy 50-100F | $\leq 0,21$ | DN 50 (flanged) | - | 10 ÷ 180 | 0,1 ÷ 1,5 | 9,8 |

TECHNICAL FEATURES - twin

| Model | EEl (energy efficiency index) | Pipe connection | Inlet fitting | Power P_1 [W] $P_{min} - P_{max}$ | Current consumption [A] $I_{min} - I_{max}$ | Weight [kg] |
|--------------------|-------------------------------|-----------------|---------------|--|--|-------------|
| Ego T easy 32-60 | $\leq 0,21$ | G 2" | Rp 1"¼ | 10 ÷ 90 | 0,1 ÷ 0,75 | 8,2 |
| Ego T easy 32-80 | $\leq 0,21$ | G 2" | Rp 1"¼ | 10 ÷ 140 | 0,1 ÷ 1,15 | 8,2 |
| Ego T easy 32-100 | $\leq 0,21$ | G 2" | Rp 1"¼ | 10 ÷ 180 | 0,1 ÷ 1,50 | 8,2 |
| Ego T easy 40-100F | $\leq 0,21$ | DN 40 (flanged) | - | 10 ÷ 180 | 0,1 ÷ 1,50 | 11,0 |

THREADED/FLANGED CIRCULATORS

Ego (T) (C) easy -60, -80, -100 single and twin

DIMENSIONS - single

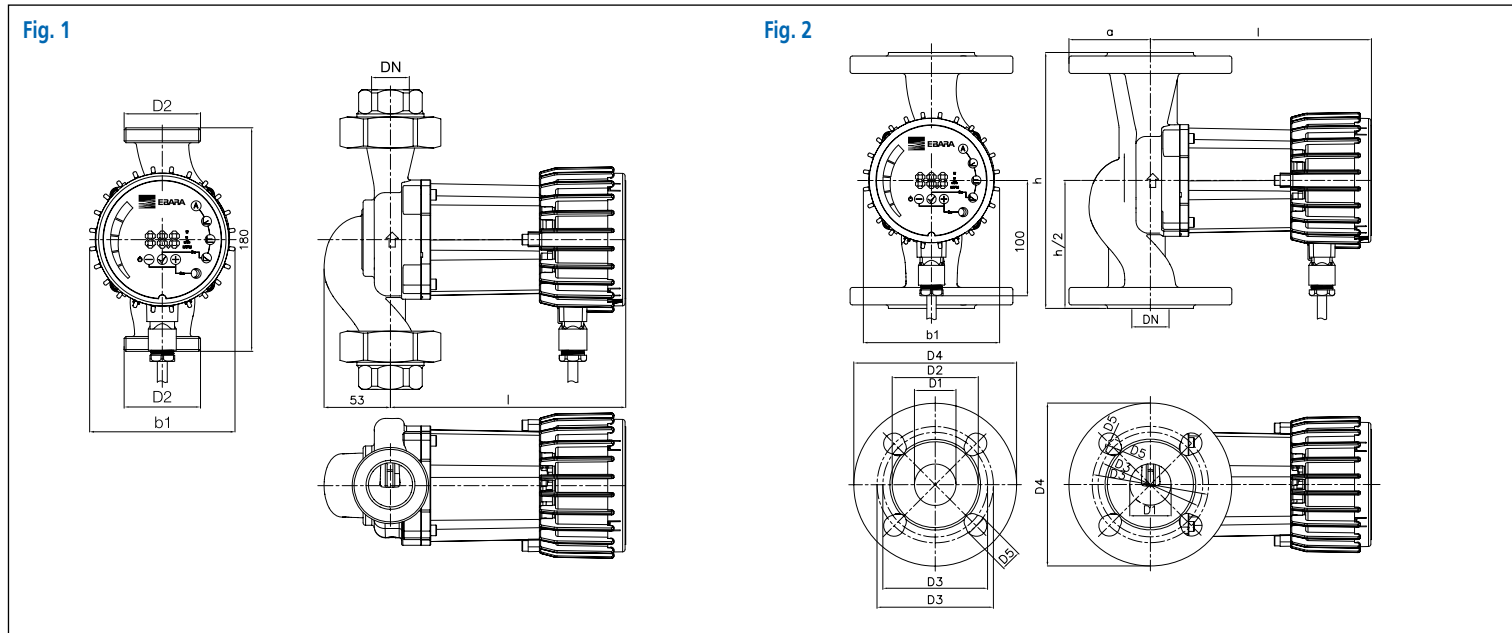

TABLE OF DIMENSIONS - single

| Rif. | Model | Dimensions [mm] | | | | | | | | | | |
|--------|------------------|-----------------|----|-----|------------|------|----|--------|---------|-----|-------|-------------|
| | | h | DN | b1 | l | a | D1 | D2 | D3 | D4 | D5 | n. of holes |
| Fig. 1 | Ego easy 25-60 | 180 | 25 | 117 | 190 (222)* | - | - | 1" 1/2 | - | - | - | - |
| | Ego easy 32-60 | 180 | 32 | 117 | 190 (222)* | - | - | 2" | - | - | - | - |
| | Ego easy 25-80 | 180 | 25 | 117 | 190 (222)* | - | - | 1" 1/2 | - | - | - | - |
| | Ego easy 32-80 | 180 | 32 | 117 | 190 (222)* | - | - | 2" | - | - | - | - |
| | Ego easy 25-100 | 180 | 25 | 117 | 190 (222)* | - | - | 1" 1/2 | - | - | - | - |
| | Ego easy 32-100 | 180 | 32 | 117 | 190 (222)* | - | - | 2" | - | - | - | - |
| Fig. 2 | Ego easy 32-100F | 220 | 32 | 117 | 190 (222)* | 70 | 32 | 74 | 90/100 | 140 | 14/18 | 4 |
| | Ego easy 40-100F | 220 | 40 | 117 | 190 (222)* | 75 | 40 | 80 | 100/110 | 150 | 14/19 | 4 |
| | Ego easy 50-100F | 240 | 50 | 117 | 190 (222)* | 82,5 | 50 | 90 | 110/125 | 165 | 14/19 | 4 |

* Dimensions in bracket are referred to Ego easy C (version with communication module)

THREADED/FLANGED CIRCULATORS

Ego (T) (C) easy -60, -80, -100 single and twin

DIMENSIONS - twin

Fig. 1

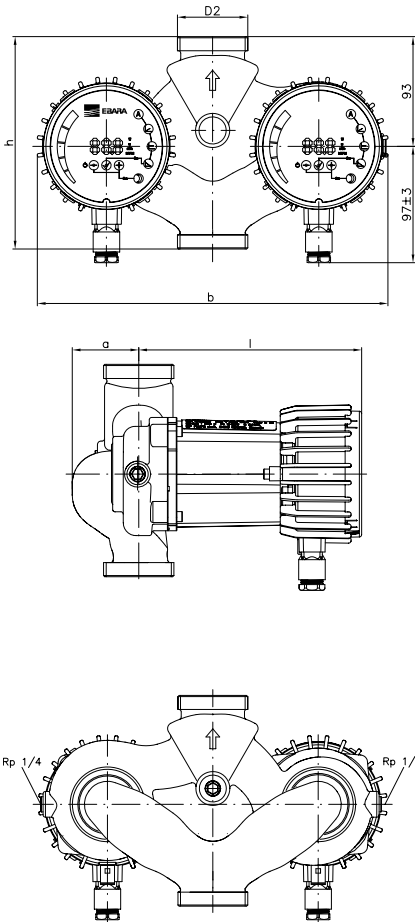
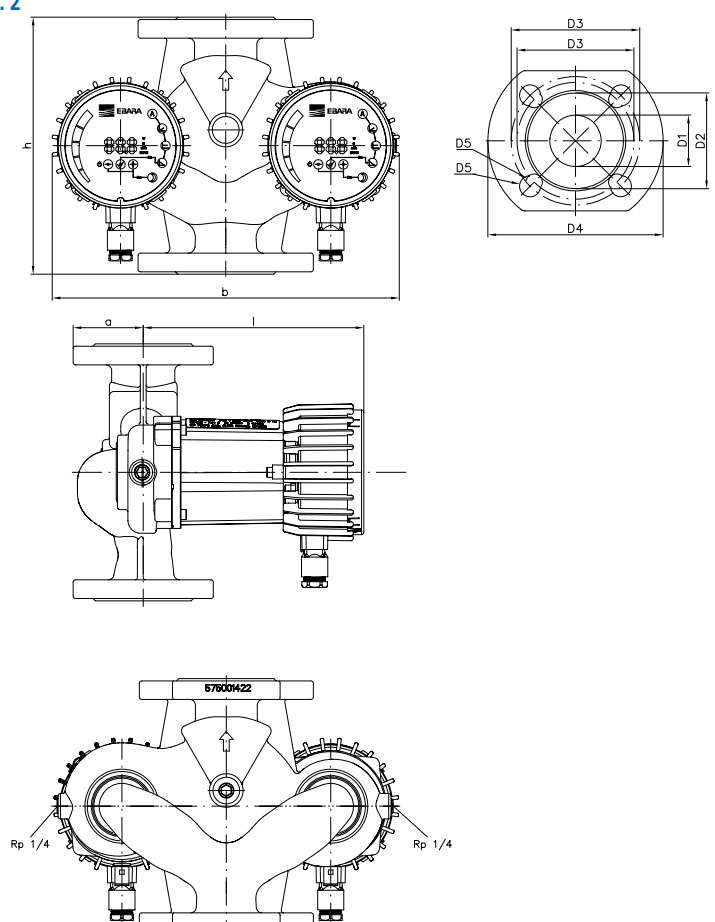

Fig. 2



DIMENSIONS - twin

| Rif. | Model | h | DN | b | l | a | Dimensions [mm] | | | | | n. of holes |
|--------|--------------------|-----|----|-----|------------|----|-----------------|----|---------|-----|-------|-------------|
| | | | | | | | D1 | D2 | D3 | D4 | D5 | |
| Fig. 1 | Ego T easy 32-60 | 180 | 32 | 297 | 190 (222)* | 56 | - | 2" | - | - | - | - |
| | Ego T easy 32-80 | 180 | 32 | 297 | 190 (222)* | 56 | - | 2" | - | - | - | - |
| | Ego T easy 32-100 | 180 | 32 | 297 | 190 (222)* | 56 | - | 2" | - | - | - | - |
| Fig. 2 | Ego T easy 40-100F | 220 | 40 | 297 | 190 (222)* | 75 | 40 | 80 | 100/110 | 150 | 14/19 | 4 |

* Dimensions in bracket are referred to Ego easy C (version with communication module)

THREADED/FLANGED CIRCULATORS

Ego (T) (C) easy -60, -80, -100 single and twin

ASSEMBLY POSITION

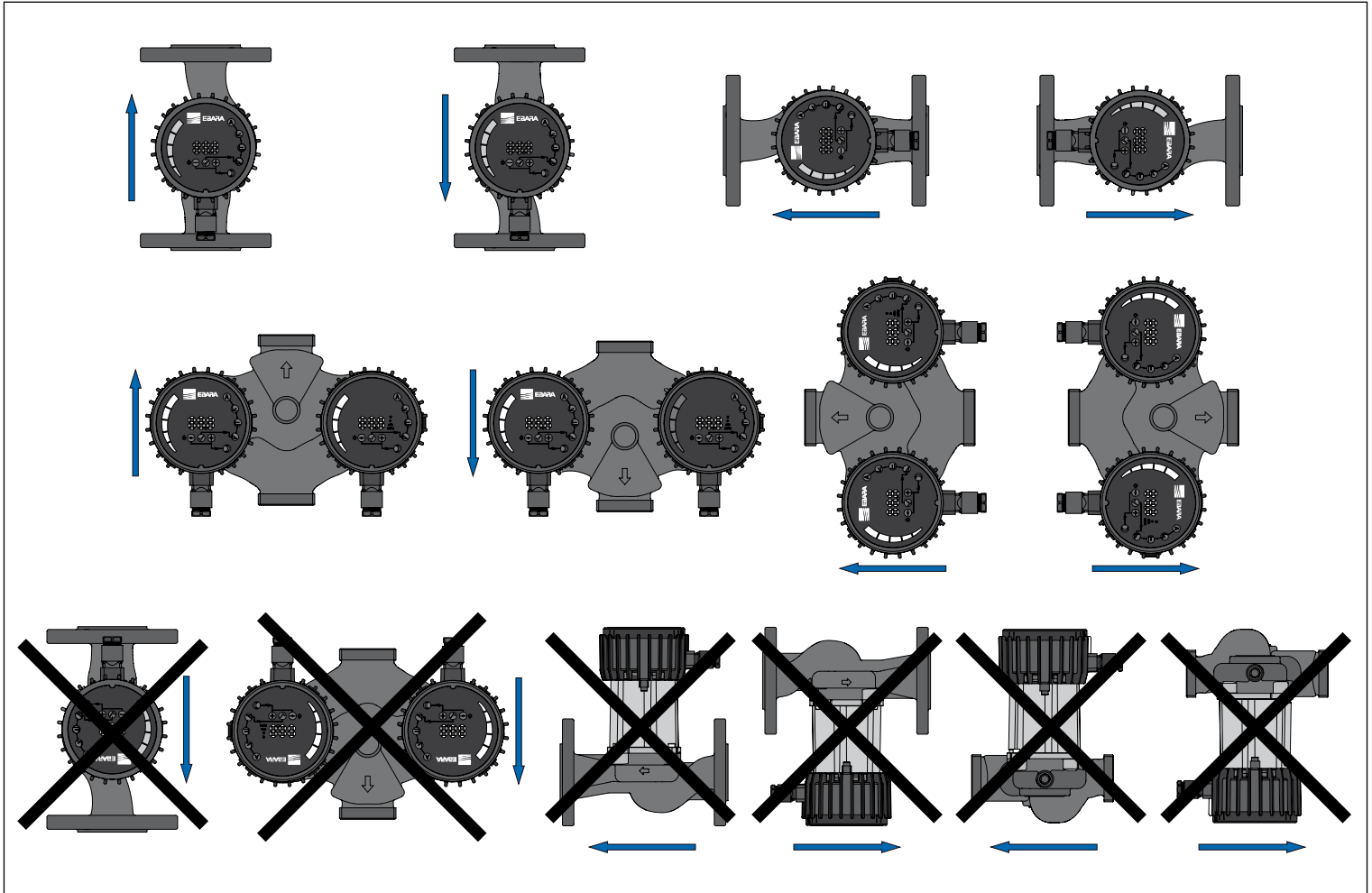

FLANGED CIRCULATORS

Ego (T) (C) 40, 50, 65, 80, 100, (H), single and twin



High performance wet rotor circulation pump with flanged connection, motor with permanent magnets and built-in electronic controller.

APPLICATIONS

Residential and industrial heating and air-conditioning systems.

FEATURES

- Built-in frequency converter
- Multiple operating modes
- Numeric and graphical display for easy setup and visualisation of parameters
- Automatic venting function
- Built-in overload safety device
- High input torque (with consequent automatic release of the rotor)
- Ethernet connection, digital inputs and relays included (standard)
- Optional version with built-in communication module (with Modbus, contact 0-10V etc.)

PUMP TECHNICAL DATA

- Liquid temperature: $-10 \div +110$ °C
- Room temperature: $0 \div +40$ °C
- Relative air humidity: $\leq 95\%$
- Allowed fluids: clean, non aggressive and not flammable, free of solid particles or fibres
- Maximum pressure: 10 bar
- Minimum suction pressure:
 - 0,3 bar to 50 °C
 - 1,1 bar to 80 °C
 - 1,6 bar to 110 °C
- Maximum amount of glycol: 20%*
- Flanged inlets: from DN 40 to DN 100
- Protection degree: IP44

MOTOR TECHNICAL DATA

- Type: synchronous with permanent magnets
- Motor speed: variable
- Supply voltage: 1~230V
- Frequency: 50/60 Hz
- Insulation class: F

* For greater amounts please check the final viscosity and the conditions of use.

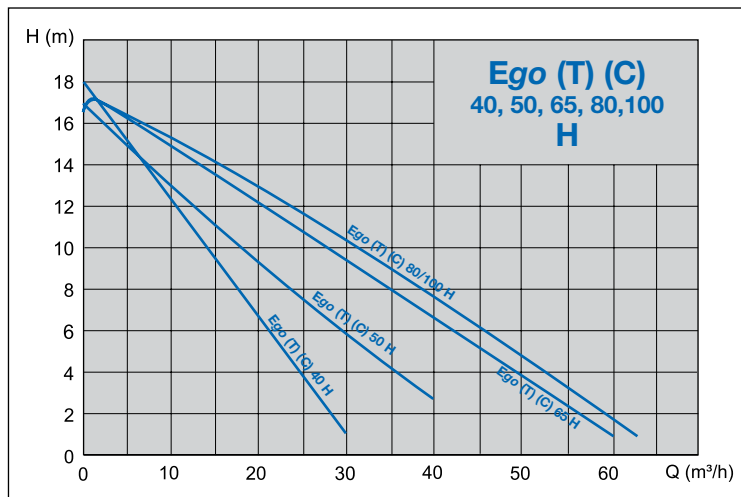
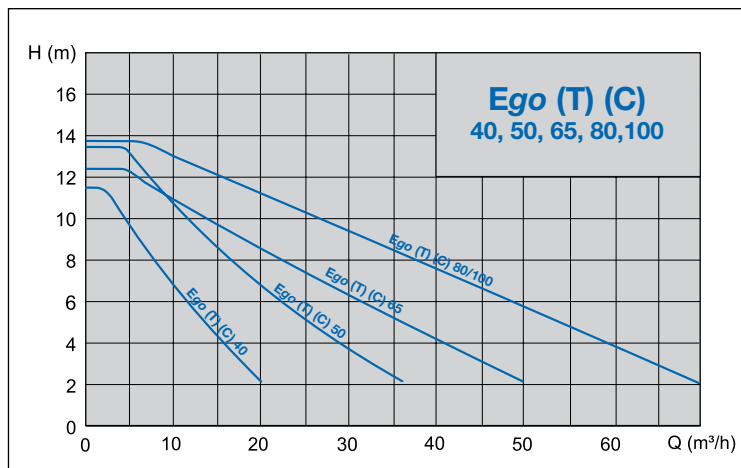

IDENTIFICATION CODE

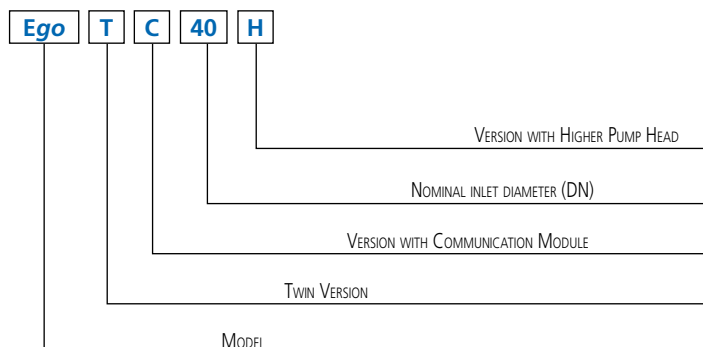

The content of this publication should not be considered mandatory. EBARA Pumps Europe S.p.A. reserves the right to change the content without prior notice.

FLANGED CIRCULATORS

Ego (T) (C) 40, 50, 65, 80, 100, (H), single and twin

OPERATING MODES

The operating modes can be selected using the buttons located on the rear panel:

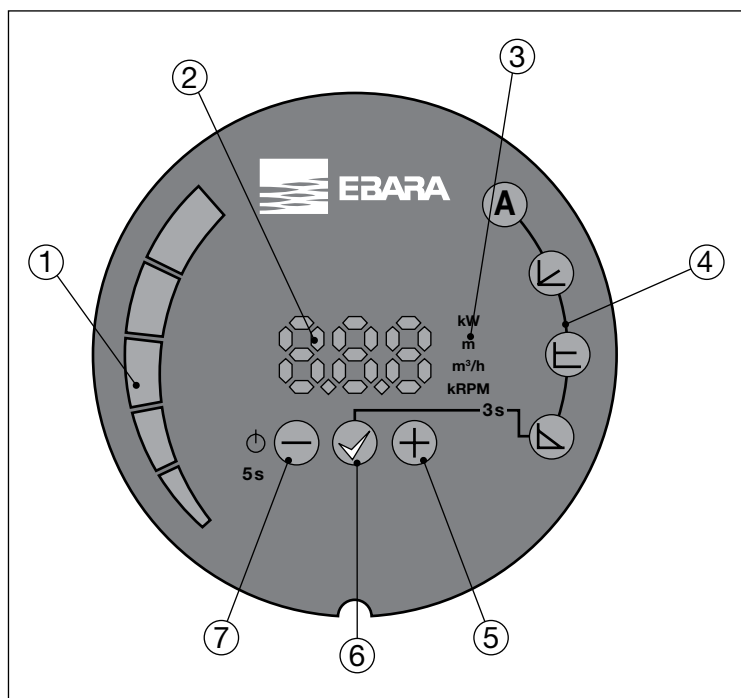

KEY

- 1 Segment display
- 2 Numeric display
- 3 Display of selected parameter
- 4 Display of selected mode
- 5 Selection key
- 6 Confirmation key
- 7 Selection key

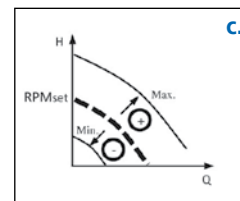
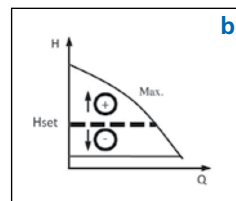
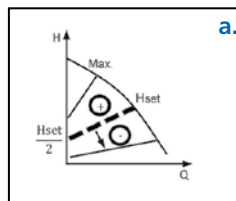

- A AUTO mode (factory setting)**
The circulator automatically adjusts the hydraulic performance depending on the actual requirements of the system, continuously measuring the optimal H/Q point. This operating mode is suitable for most applications and ensures high energy savings.
- Proportional pressure ($\Delta P-v$) - fig. a**
The circulator adjusts the pump head depending on the flow rate, varying the latter linearly from a maximum value (H_{set}) to a minimum value (equal to $H_{set}/2$). The pressure value (H_{set}) is set via buttons \oplus and \ominus and is expressed in metres; the minimum value is automatically calculated by the circulator.
- Constant pressure ($\Delta P-c$) - fig. b**
The circulators maintains the pump head constant when the flow rates varies. The value of the pressure (H_{set}) is set via buttons \oplus and \ominus and is expressed in metres.
- Constant speed - fig. c**
The circulators operates according to a constant curve set via buttons \oplus and \ominus (by selecting the rotation speed in "rpm").

REMOTE CONTROL

Standard configuration

The standard configuration of circulators Ego (T) 40-50-65-80-100 provides:

- Ethernet connection for control via PC
- Digital inputs
- Output relay

Upon request

Upon request, the "Ego C" version equipped with an additional communication module is available. It includes the following:

- Analog control 0-10V
- Modbus RTU

FLANGED CIRCULATORS

Ego (T) (C) 40, 50, 65, 80, 100, (H), single and twin

PERFORMANCE CURVES

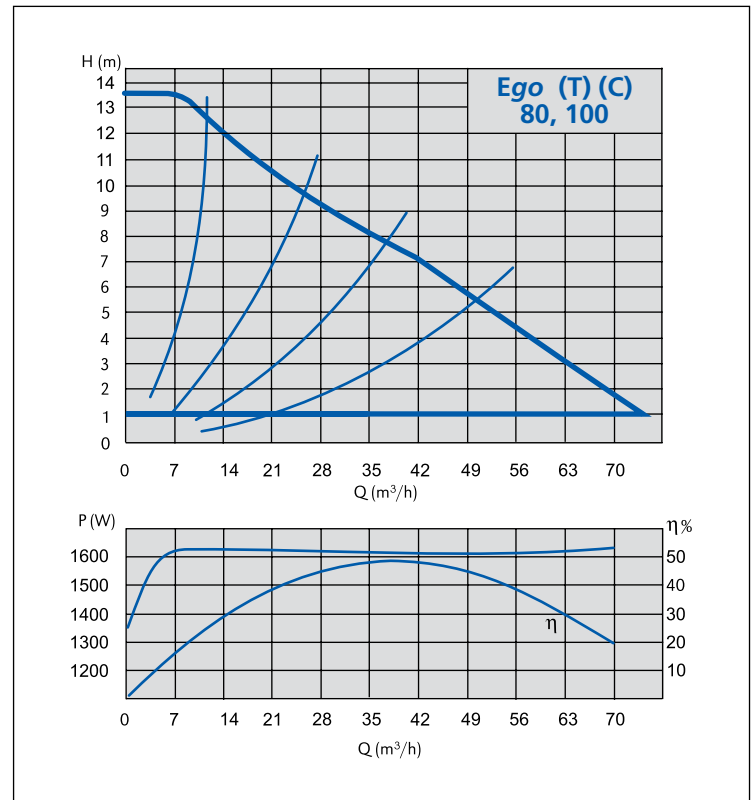
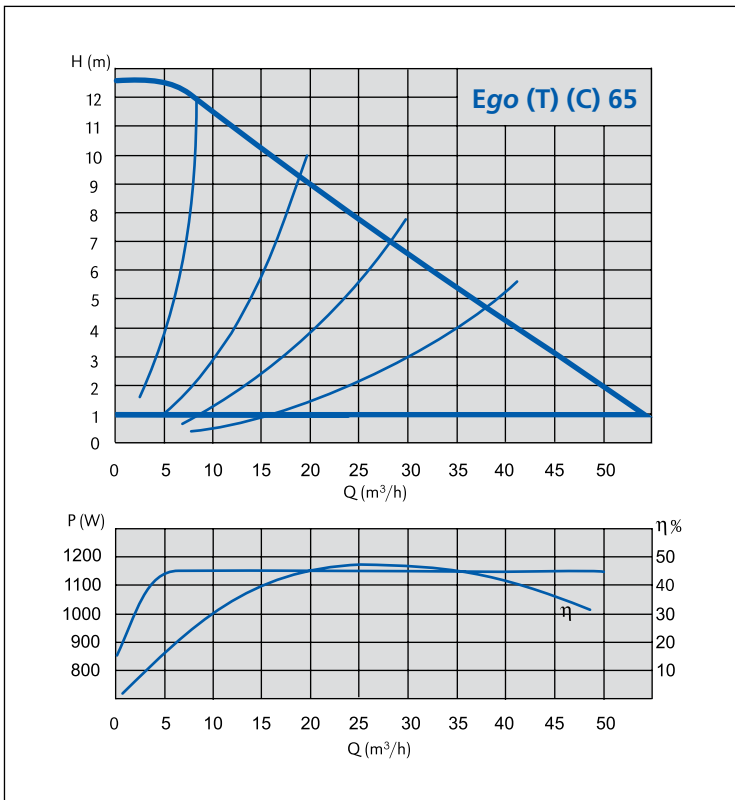
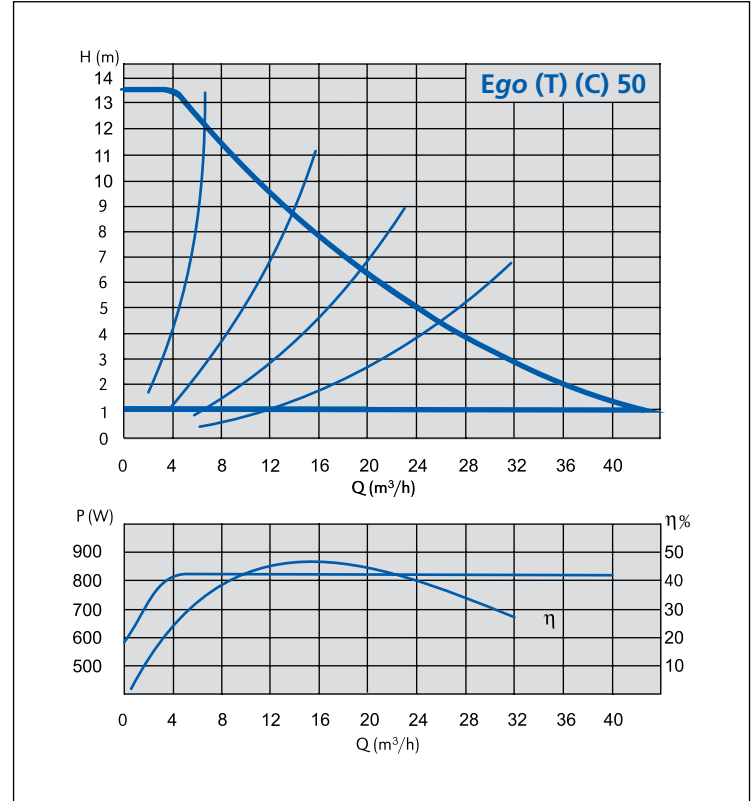
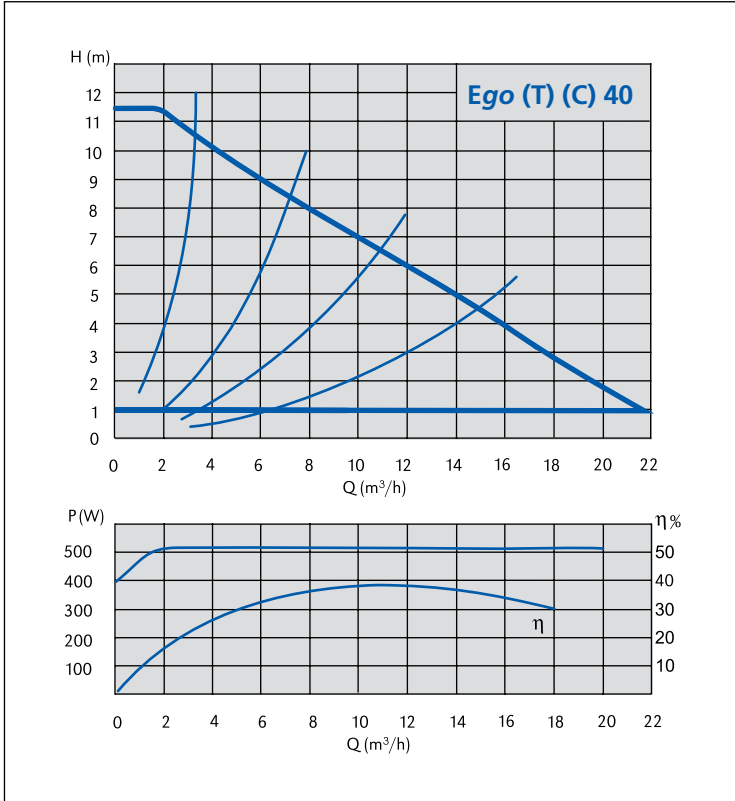

The content of this publication should not be considered mandatory. EBARA Pumps Europe S.p.A. reserves the right to change the content without prior notice.

FLANGED CIRCULATORS

Ego (T) (C) 40, 50, 65, 80, 100, (H), single and twin

PERFORMANCE CURVES

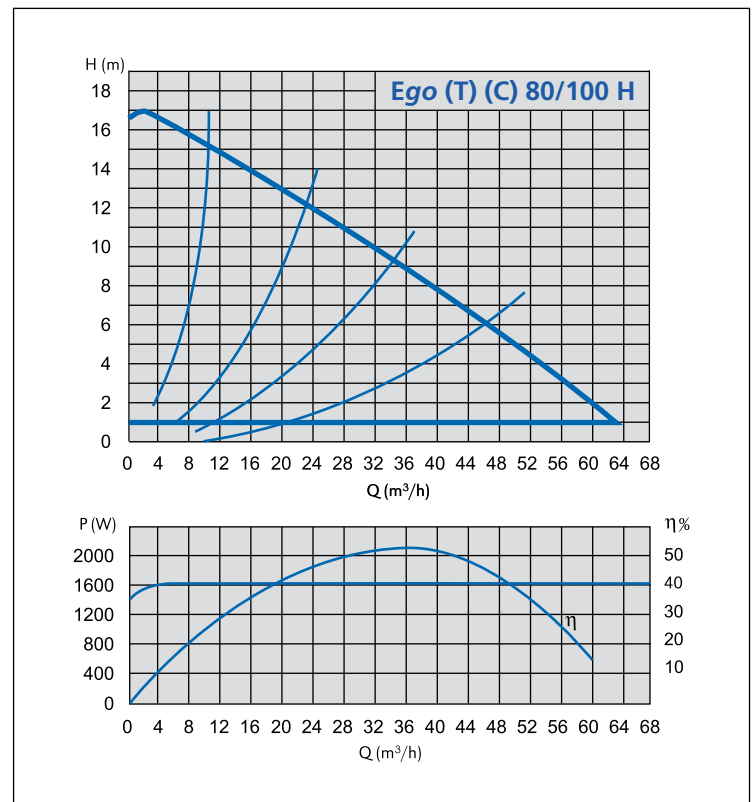
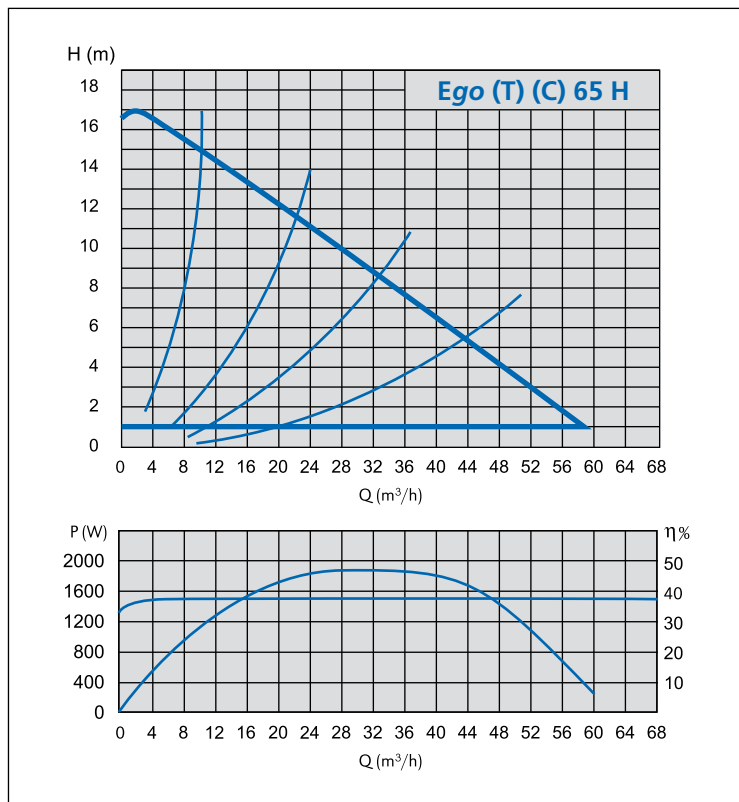
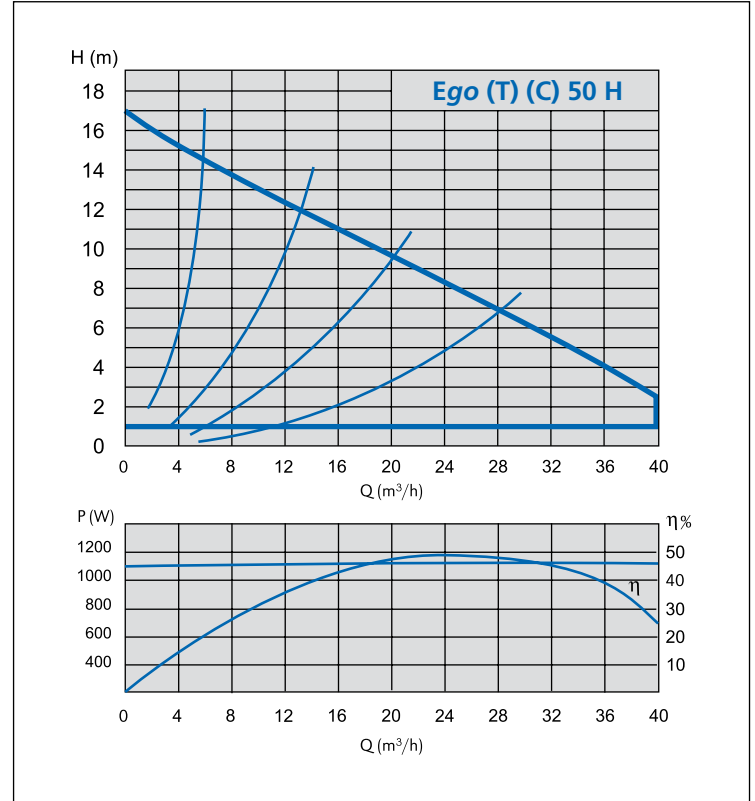
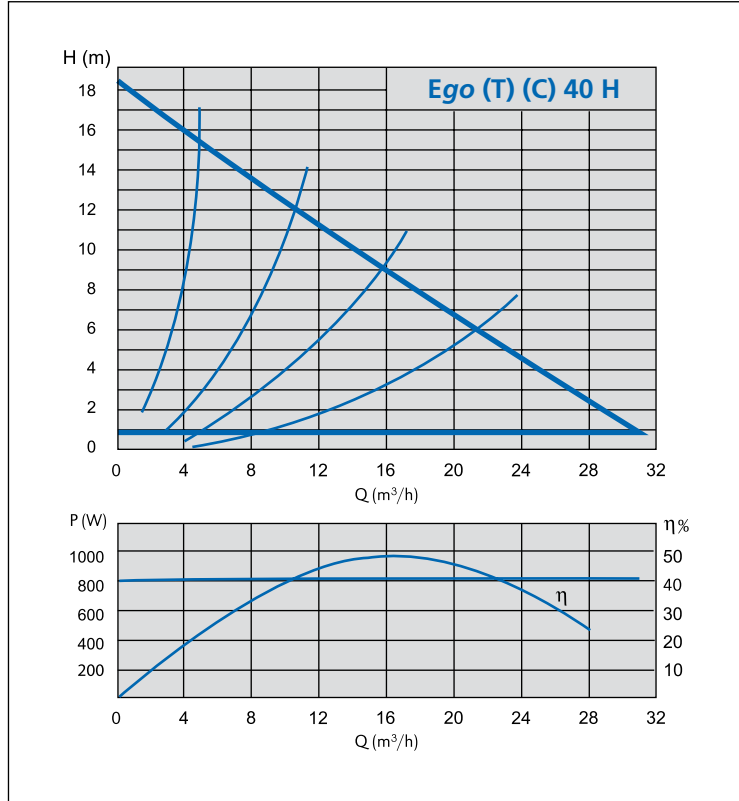

FLANGED CIRCULATORS

Ego (T) (C) 40, 50, 65, 80, 100, (H), single and twin

SECTIONAL VIEW

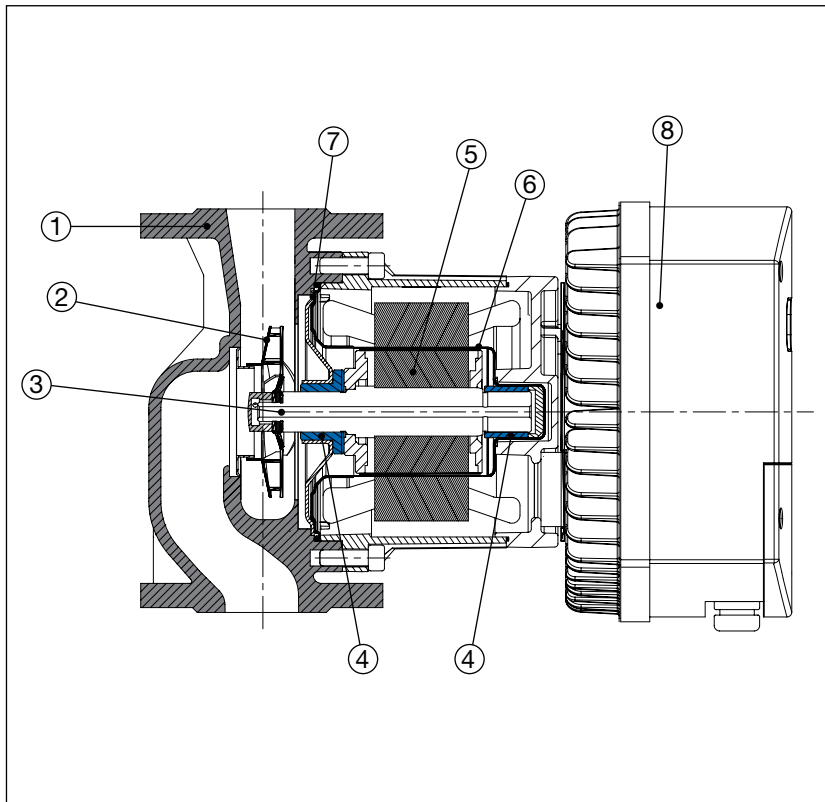

TABLE OF MATERIALS

| Ref. | Part | Material |
|------|------------------|---------------------------|
| 1 | Pump body | Cast iron |
| 2 | Impeller | Stainless steel |
| 3 | Shaft | Stainless steel |
| 4 | Bearings | Graphite |
| 5 | Rotor | Coated in stainless steel |
| 6 | Rotor can | AISI 316 Stainless Steel |
| 7 | Bearing plate | AISI 316 Stainless Steel |
| 8 | Electronic board | - |

TECHNICAL FEATURES - single

| Model | EEI (energy efficiency index) | Pipe connection | Power P_1 [W] $P_{min} - P_{max}$ | Current consumption [A] $I_{min} - I_{max}$ | Weight [kg] |
|-----------|----------------------------------|-----------------|--|--|-------------|
| Ego 40 | $\leq 0,27$ | DN40 | 20 - 500 | 2,2 | 25,0 |
| Ego 40 H | $\leq 0,27$ | DN40 | 20 - 800 | 3,6 | 29,0 |
| Ego 50 | $\leq 0,26$ | DN50 | 26 - 800 | 3,5 | 31,0 |
| Ego 50 H | $\leq 0,26$ | DN50 | 20 - 1100 | 4,8 | 30,0 |
| Ego 65 | $\leq 0,25$ | DN65 | 38 - 1100 | 4,8 | 36,0 |
| Ego 65 H | $\leq 0,25$ | DN65 | 20 - 1500 | 6,7 | 39,0 |
| Ego 80 | $\leq 0,23$ | DN80 | 45 - 1600 | 6,9 | 42,0 |
| Ego 80 H | $\leq 0,24$ | DN80 | 20 - 1600 | 7,3 | 41,0 |
| Ego 100 | $\leq 0,23$ | DN100 | 45 - 1600 | 6,9 | 46,0 |
| Ego 100 H | $\leq 0,23$ | DN100 | 20 - 1600 | 7,2 | 45,0 |

TECHNICAL FEATURES - twin

| Model | EEI (energy efficiency index) | Pipe connection | Power P_1 [W] $P_{min} - P_{max}$ | Current consumption [A] $I_{min} - I_{max}$ | Weight [kg] |
|------------|----------------------------------|-----------------|--|--|-------------|
| Ego T 40 | $\leq 0,27$ | DN40 | 20 - 500 | 2,2 | 47,0 |
| Ego T 40 H | $\leq 0,27$ | DN40 | 20 - 800 | 3,6 | 57,0 |
| Ego T 50 | $\leq 0,26$ | DN50 | 26 - 800 | 3,5 | 60,0 |
| Ego T 50 H | $\leq 0,26$ | DN50 | 20 - 1100 | 4,8 | 60,0 |
| Ego T 65 | $\leq 0,25$ | DN65 | 38 - 1100 | 4,8 | 66,0 |
| Ego T 65 H | $\leq 0,25$ | DN65 | 20 - 1500 | 6,7 | 74,0 |
| Ego T 80 | $\leq 0,23$ | DN80 | 45 - 1600 | 6,9 | 77,0 |
| Ego T 80 H | $\leq 0,24$ | DN80 | 20 - 1600 | 7,3 | 77,0 |

FLANGED CIRCULATORS

Ego (T) (C) 40, 50, 65, 80, 100, (H), single and twin

DIMENSIONS - single

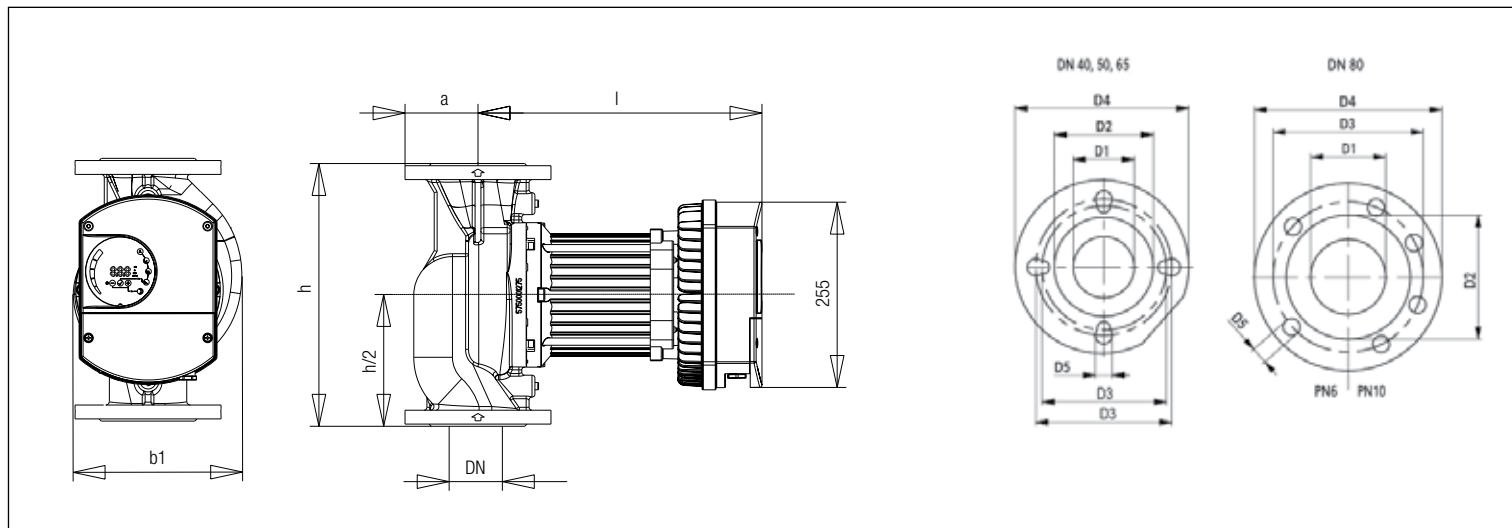

TABLE OF DIMENSIONS - single

| Model | DN | b1 | b4 | l | h | Dimensions [mm] | | | | | | | n. of holes |
|-----------|-----|-----|----|-----|-----|-----------------|-----|-----|-----|---------|-----|-------|-------------|
| | | | | | | h1 | a | D1 | D2 | D3 | D4 | D5 | |
| Ego 40 | 40 | 198 | - | 321 | 250 | - | 65 | 40 | 80 | 100/110 | 150 | 14/19 | 4 |
| Ego 40 H | 40 | 198 | - | 355 | 250 | - | 65 | 40 | 80 | 100/110 | 150 | 14/19 | 4 |
| Ego 50 | 50 | 200 | - | 355 | 280 | - | 70 | 50 | 90 | 100/125 | 165 | 14/19 | 4 |
| Ego 50 H | 50 | 200 | - | 355 | 280 | - | 70 | 50 | 90 | 100/125 | 165 | 14/19 | 4 |
| Ego 65 | 65 | 222 | - | 369 | 340 | - | 80 | 65 | 110 | 130/145 | 185 | 14/19 | 4 |
| Ego 65 H | 65 | 222 | - | 403 | 340 | - | 80 | 65 | 110 | 130/145 | 185 | 14/19 | 4 |
| Ego 80 | 80 | 230 | - | 403 | 360 | - | 100 | 80 | 128 | 160 | 200 | 19 | 8 |
| Ego 80 H | 80 | 230 | - | 403 | 360 | - | 100 | 80 | 128 | 160 | 200 | 19 | 8 |
| Ego 100 | 100 | 230 | - | 403 | 360 | - | 110 | 100 | - | 180 | 220 | 19 | 8 |
| Ego 100 H | 100 | 230 | - | 403 | 360 | - | 110 | 100 | 140 | 180 | 220 | 19 | 8 |

FLANGED CIRCULATORS

Ego (T) (C) 40, 50, 65, 80, 100, (H), single and twin

DIMENSIONS - twin

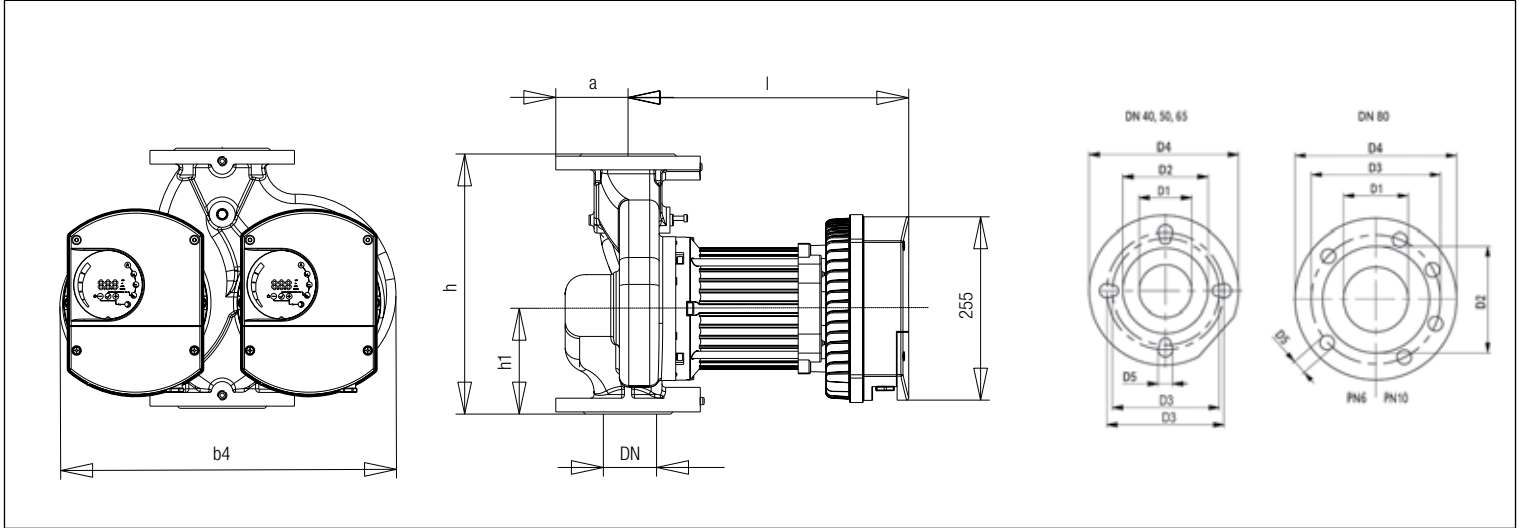

DIMENSIONS - twin

| Model | DN | b1 | b4 | l | h | Dimensions [mm] | | D1 | D2 | D3 | D4 | D5 | n. of holes |
|------------|----|----|-----|-----|-----|-----------------|-----|----|-----|---------|-----|-------|-------------|
| | | | | | | h1 | a | | | | | | |
| Ego T 40 | 40 | - | 403 | 321 | 250 | 110 | 65 | 40 | 80 | 100/110 | 150 | 14/19 | 4 |
| Ego T 40 H | 40 | - | 403 | 355 | 250 | 110 | 65 | 40 | 80 | 100/110 | 150 | 14/19 | 4 |
| Ego T 50 | 50 | - | 403 | 355 | 280 | 121 | 70 | 50 | 90 | 100/125 | 165 | 14/19 | 4 |
| Ego T 50 H | 50 | - | 403 | 355 | 280 | 121 | 70 | 50 | 90 | 100/125 | 165 | 14/19 | 4 |
| Ego T 65 | 65 | - | 452 | 369 | 340 | 141 | 80 | 65 | 110 | 130/145 | 185 | 14/19 | 4 |
| Ego T 65 H | 65 | - | 452 | 403 | 340 | 141 | 80 | 65 | 110 | 130/145 | 185 | 14/19 | 4 |
| Ego 80 H | 80 | - | 462 | 403 | 360 | 146 | 100 | 80 | 128 | 160 | 200 | 19 | 8 |
| Ego T 80 H | 80 | - | 462 | 403 | 360 | 146 | 100 | 80 | 128 | 160 | 200 | 19 | 8 |

FLANGED CIRCULATORS

Ego (T) (C) 40, 50, 65, 80, 100, (H), single and twin

ASSEMBLY POSITION



EBARA Pumps Europe network

HEAD OFFICE

EBARA Pumps Europe S.p.A.
Via Pacinotti, 32
36040 Brendola (VI), Italia
Phone +39 0444 706811 - Fax +39 0444 405811

Italian Sales (for order only):
e-mail: ordini@ebaraeurope.com

Export Sales (for order only):
e-mail: exportsales@ebaraeurope.com

Technical Customer Service (TCS):
e-mail: tcs@ebaraeurope.com
Phone +39 0444 706869/902/923/833

Marketing & Marketing Communication:
e-mail: marketing@ebaraeurope.com

ITALIAN SALES NETWORK

Area NORD-EST:
(Trentino Alto Adige, Veneto, Friuli Venezia Giulia, Emilia Romagna)
Regional Manager mobile: +39 335 6423308
e-mail: nord@ebaraeurope.com
Phone +39 0444 706811 - Fax +39 0444 405811

Area NORD-OVEST:
(Valle d'Aosta, Piemonte, Lombardia, Liguria)
Regional Manager mobile: +39 335 5327276
e-mail: mrtgmi@ebaraeurope.com
Phone +39 0444 706811 - Fax +39 0444 405975

Area CENTRO:
(Toscana, Umbria, Marche, Lazio, Abruzzo, Molise)
Regional Manager mobile: +39 335 6423286
e-mail: centro@ebaraeurope.com
Phone +39 0444 706811 - Fax +39 0444 405811

Area SUD:
(Campania, Basilicata, Puglia, Calabria, Sicilia)
Regional Manager mobile: +39 335 6423316
e-mail: sud@ebaraeurope.com
Phone +39 0444 706811 - Fax +39 0444 405811

Divisione INDUSTRIA:
Manager mobile: +39 335 6423302
e-mail: industry@ebaraeurope.com
Phone +39 0444 706811 - Fax +39 0444 405811

Divisione ACQUE REFLUE:
Manager mobile: +39 335 6423290
e-mail: ses@ebaraeurope.com
Phone +39 0444 706811 - Fax +39 0444 405811

Filiale CAGLIARI:
Via del Fangario, 29
09122 Cagliari
Phone +39 070 274281 - Fax +39 0444 405960
Branch Manager mobile: +39 335 6423320
e-mail: mktgca@ebaraeurope.com

Filiale PALERMO:
Via Don L. Sturzo, 181/183
Z.I. - 90044 Carini (PA)
Phone +39 091 8669790 - Fax +39 0444 405980
Branch Manager mobile: +39 335 6423316
e-mail: mktgpa@ebaraeurope.com

EXPORT NETWORK

EBARA Pumps Europe S.p.A. UNITED KINGDOM
Unit 7 - Zodiac Business Park
High Road - Cowley Uxbridge
Middlesex - UB8 2GU, United Kingdom
Phone +44 1895 439027 - Fax +44 1895 439028
e-mail: mktguk@ebaraeurope.com

EBARA ESPAÑA BOMBAS S.A.
C/Cormoranes 6 Y 8
Poligono Ind. La Estación
28320 Pinto (Madrid), Spain
Phone +34 916.923.630 - Fax +34 916.910.818
e-mail: marketing@ebara.es

EBARA Pumps Europe S.p.A. FRANCE
555, Rue Juliette Recamier
69970 Chaponnay, France
Phone +33 4 72769482 - Fax +33 805101071
e-mail: mktgfr@ebaraeurope.com

EBARA Pumps Europe S.p.A. GERMANY
Ferdinand-Porsche-Ring 7
63110 Rodgau-Jügesheim, Germany
Phone +49 (0) 6106-660 99-0
Fax +49 (0) 6106-660 99-45
e-mail: mktgde@ebaraeurope.com

EBARA POMPY POLSKA Sp. z o.o.
ul. Działkowa 115
02-234 Warszawa, Poland
Phone +48 22 3909920 - Fax +48 22 3909929
e-mail: mktgpl@ebaraeurope.com

EBARA Pumps Europe S.p.A. MIDDLE EAST
P.O. Box 54515
Dubai Airport Free Zone
Dubai, United Arab Emirates
Phone +971 4 609 1040 - Fax +971 4 609 1038
e-mail: mktgme@ebaraeurope.com

EBARA Pumps Europe S.p.A. SAUDI ARABIA
Phone +966 11 810 4561
Fax +966 11 810 4562

EBARA Pumps Europe S.p.A INDIA LIAISON OFFICE
1503, Bhumiraj Costarica,
Sector-18, Palm Beach Rd.
Sanpada, Navi Mumbai
Maharashtra, Pin: 400705 - India
Phone +91 22 2781 2862
Fax +91 22 2781 2865
e-mail: mktgind@ebaraeurope.com

EBARA Pumps RUS Ltd.
Prospekt Andropov 18, building 7, floor 11
115432 Moscow
Japan
Phone +7 499 6830133
e-mail: mktgrus@ebaraeurope.com



EBARA Pumps Europe S.p.A.

Via Pacinotti, 32
36040 Brendola (Vicenza), Italy
Phone +39 0444 706811 - Fax +39 0444 405811
e-mail: marketing@ebaraeurope.com
www.ebaraeurope.com



EBARA Corporation

11-1, Haneda Asahi-cho, Ohta-ku,
Tokyo 144-8510
Japan
Phone +81 3 6275 7598 - Fax +81 3 5736 3193
www.ebara.com

