



# MR B -/40-130

## CIRCULATING PUMP FOR SANITARY WATER SYSTEMS

Threaded



### PERFORMANCE CURVES (according to ISO 9906 Attachment A)

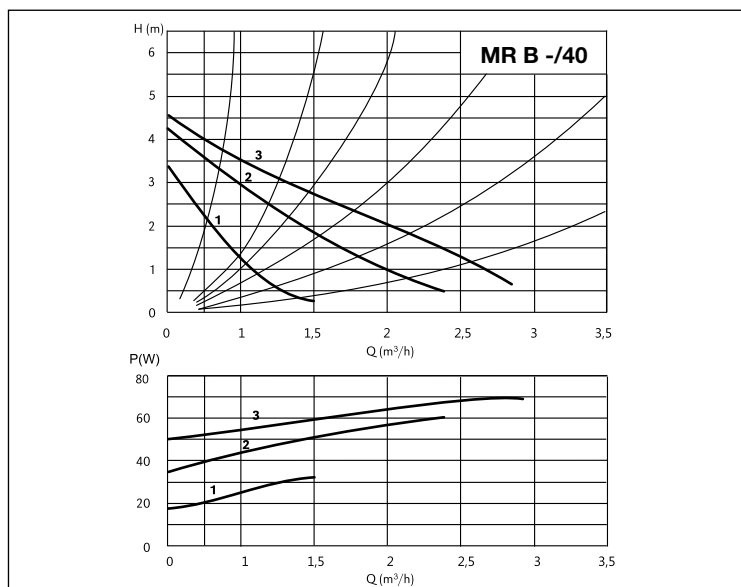

### DIMENSIONS

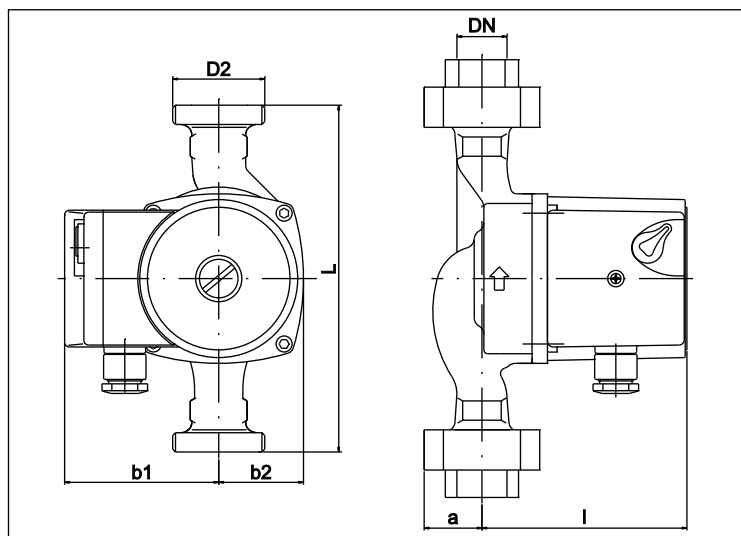

### TECHNICAL FEATURES

Model	Centre-to-centre distance [mm]	DN	Pump connection	Pipeline connection	Fluid temperature (min - max °C)	PN [bar]	P1 max [W]	In max 1~230V [A]	Minimum suction pressure [bar]			Weight [kg]
									50°C	80°C	110°C	
MR B 15/40-130	130	DN15	G 1"	Rp ½"	+5 +65	10	75	0,33	0,05	0,4	1,1	2,3
MR B 25/40-130	130	DN25	G 1 ½"	Rp 1"	+5 +65	10	75	0,33	0,05	0,4	1,1	2,4

### APPLICATIONS

Circulating pump for sanitary water systems

### TECHNICAL DATA

- Fixed speed (3 selectable speed levels)
- Supply Voltage 1~230V - 50Hz
- Insulation class: H
- Protection rating: IP44
- Maximum operating pressure: 10 bar
- Maximum ambient temperature: 40°C
- Liquid temperature range: +5°C to +65°C

### MATERIALS

- Pump casing in bronze
- Runner in polyamide
- Shaft in stainless steel
- Radial bearing in graphite
- Separator tube and plate in stainless steel AISI 316

### PERMITTED LIQUIDS

- Liquids that are clear, clean, non-aggressive and non-explosive, with no solid particles or fibres

### IDENTIFICATION CODE

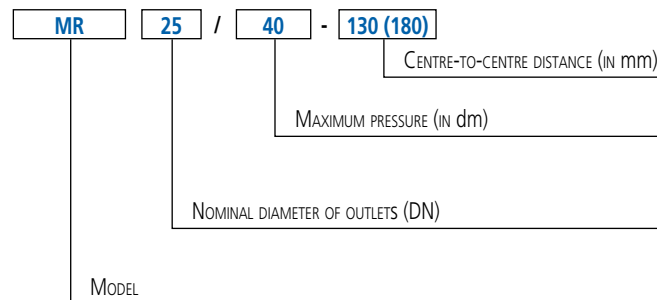

### DIMENSIONAL TABLE

Model	L	DN	b1	b2	l	a	D2
MR B 15/40-130	130	15	80	44	108	28	1"
MR B 25/40-130	130	25	80	44	108	28	1 ½"



# MR B -/60-130

## CIRCULATING PUMP FOR SANITARY WATER SYSTEMS

Threaded



### PERFORMANCE CURVES (according to ISO 9906 Attachment A)

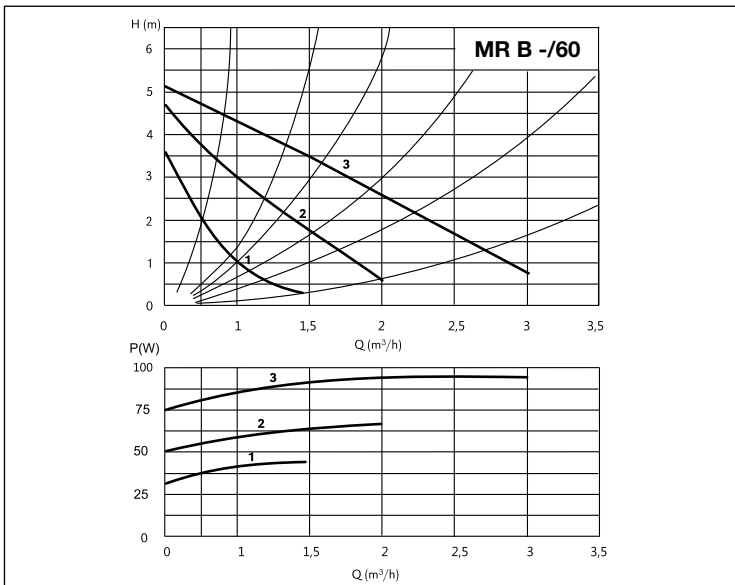

### DIMENSIONS

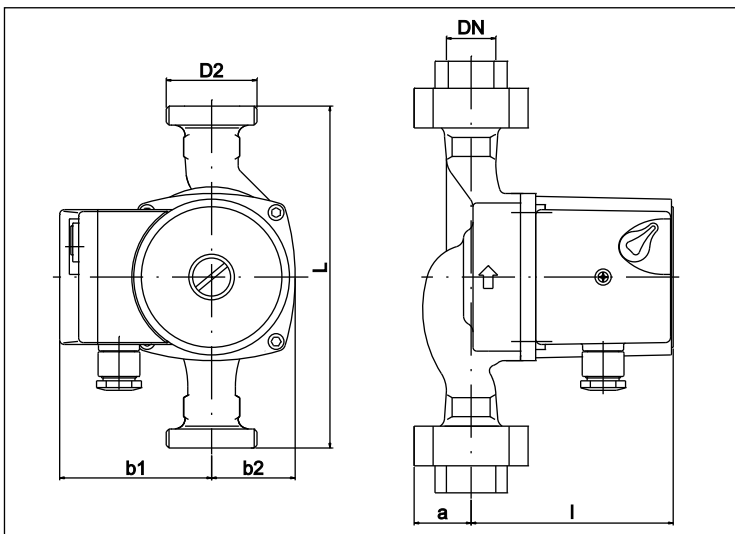

### TECHNICAL FEATURES

Model	Centre-to-centre distance [mm]	DN	Pump connection	Pipeline connection	Fluid temperature (min - max °C)	PN [bar]	P1 max [W]	In max 1~230V [A]	Minimum suction pressure [bar]			Weight [kg]
									50°C	80°C	110°C	
MR B 15/60-130	130	DN15	G 1"	Rp ½"	+5 +65	10	90	0,39	0,05	0,4	1,1	2,5
MR B 25/60-130	130	DN25	G 1"½	Rp 1"	+5 +65	10	90	0,39	0,05	0,4	1,1	2,6

### APPLICATIONS

Circulating pump for sanitary water systems

### TECHNICAL DATA

- Fixed speed (3 selectable speed levels)
- Supply Voltage 1~230V - 50Hz
- Insulation class: H
- Protection rating: IP44
- Maximum operating pressure: 10 bar
- Maximum ambient temperature: 40°C
- Liquid temperature range: +5°C to +65°C

### MATERIALS

- Pump casing in bronze
- Runner in polyamide
- Shaft in stainless steel
- Radial bearing in graphite
- Separator tube and plate in stainless steel AISI 316

### PERMITTED LIQUIDS

- Liquids that are clear, clean, non-aggressive and non-explosive, with no solid particles or fibres

### IDENTIFICATION CODE

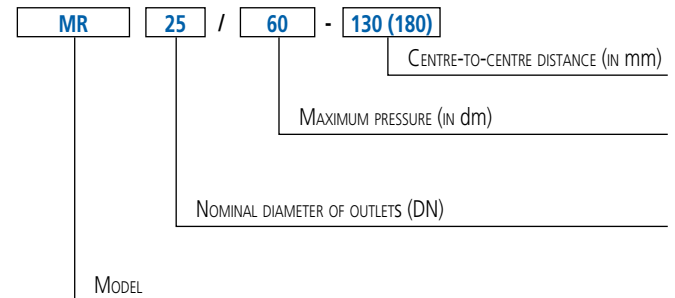

### DIMENSIONAL TABLE

Model	L	DN	b1	b2	l	a	D2
MR B 15/60-130	130	15	80	44	108	28	1"
MR B 25/60-130	130	25	80	44	108	28	1"½

The contents of this publication must not be regarded as binding. EBARA Pumps Europe S.p.A. reserves the right to effect any modification it deems necessary without prior notice.



# MR B -/70-130

## CIRCULATING PUMP FOR SANITARY WATER SYSTEMS

Threaded



### PERFORMANCE CURVES (according to ISO 9906 Attachment A)

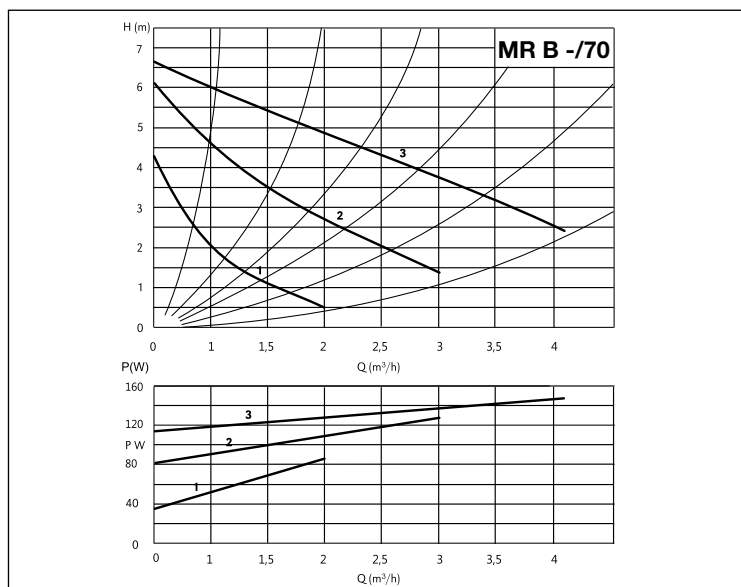

### DIMENSIONS

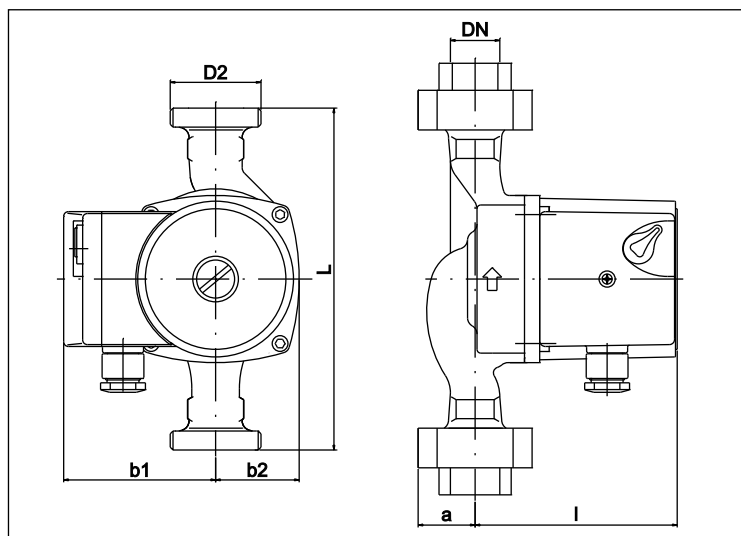

### TECHNICAL FEATURES

Model	Centre-to-centre distance [mm]	DN	Pump connection	Pipeline connection	Fluid temperature (min - max °C)	PN [bar]	P1 max [W]	In max 1~230V [A]	Minimum suction pressure [bar]			Weight [kg]
									50°C	80°C	110°C	
MR B 25/70-130	130	DN25	G 1"½	Rp 1"	+5 +65	10	140	0,62	0,05	0,4	1,1	2,6

### APPLICATIONS

Circulating pump for sanitary water systems

### TECHNICAL DATA

- Fixed speed (3 selectable speed levels)
- Supply Voltage 1~230V - 50Hz
- Insulation class: H
- Protection rating: IP44
- Maximum operating pressure: 10 bar
- Maximum ambient temperature: 40°C
- Liquid temperature range: +5°C to +65°C

### MATERIALS

- Pump casing in bronze
- Runner in polyamide
- Shaft in ceramic
- Radial bearing in ceramic
- Separator tube and plate in stainless steel AISI 316

### PERMITTED LIQUIDS

- Liquids that are clear, clean, non-aggressive and non-explosive, with no solid particles or fibres

### IDENTIFICATION CODE

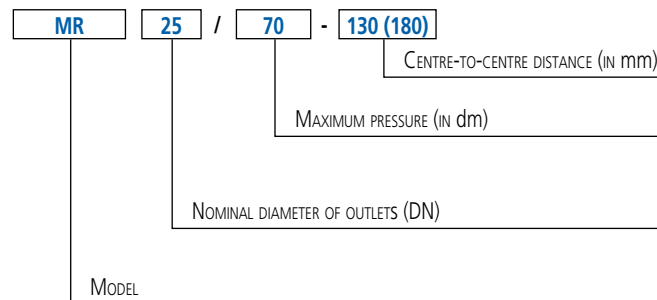

### DIMENSIONAL TABLE

Model	L	DN	b1	b2	l	a	D2
MR B 25/70-130	130	25	80	44	108	28	1"½

The contents of this publication must not be regarded as binding. EBARA Pumps Europe S.p.A. reserves the right to effect any modification it deems necessary without prior notice.